

FLOORPLAN SKETCH

Borrower:	File No.: 16538
Property Address: 18507 Square Sail Rd	Case No.:
City: Cornelius	State: NC Zip: 28031
Lender:	

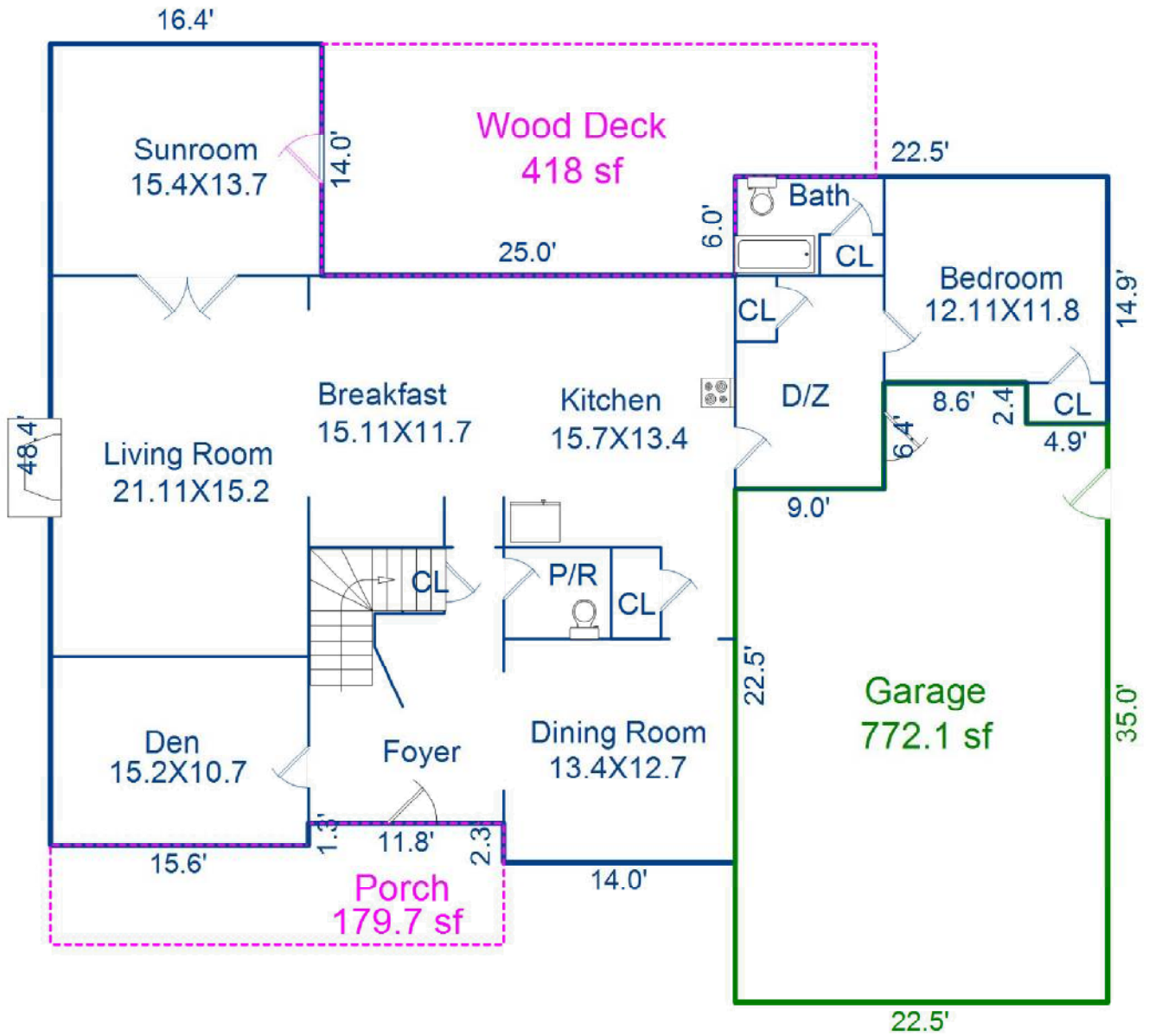

First Floor
2003 sf

Sketch by ApexSketch

AREA CALCULATIONS SUMMARY					AREA CALCULATIONS BREAKDOWN					
Code	Description	Factor	Net Size	Perimeter	Net Totals	Name	Base x	Height x	Width =	Area
GLA1	First Floor	1.0	2003.0	246.0	2003.0	First Floor		22.5 x	12.5 =	281.3
GAR	Garage	1.0	772.1	119.8	772.1			4.9 x	2.4 =	11.8
P/P	Wood Deck	1.0	418.0	95.0				9.0 x	6.4 =	57.6
	Porch	1.0	179.7	69.4	597.7			48.4 x	15.6 =	755.0
								47.1 x	0.8 =	37.7
								33.1 x	25.0 =	827.5
								14.0 x	2.3 =	32.2
	Net LIVABLE	cnt	1 (rounded)		2,003	7 total items			(rounded)	2,003

FLOORPLAN SKETCH

Borrower:	File No.: 16538
Property Address: 18507 Square Sail Rd	Case No.:
City: Cornelius	State: NC Zip: 28031
Lender:	

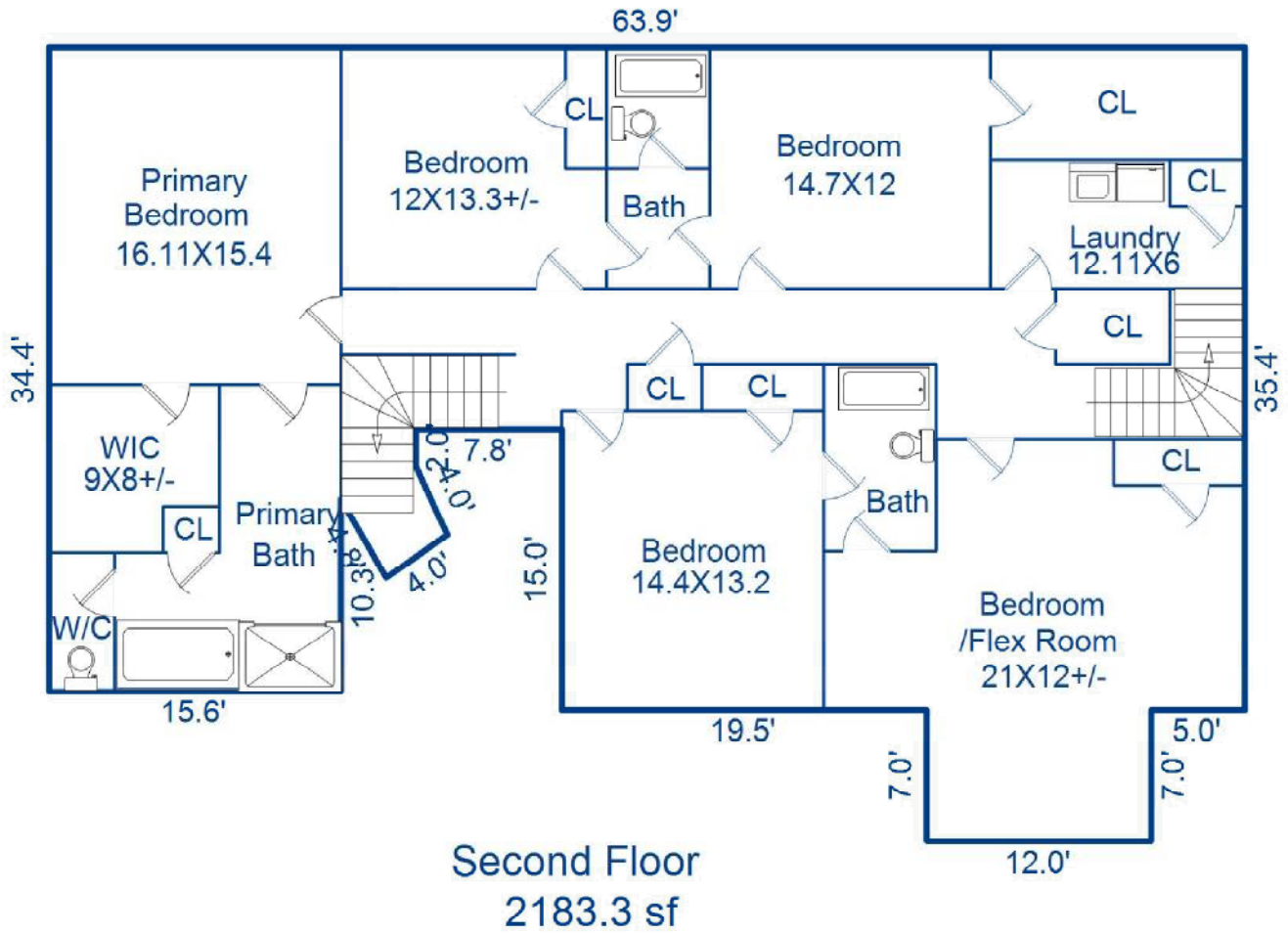

Sketch by ApexSketch

AREA CALCULATIONS SUMMARY					AREA CALCULATIONS BREAKDOWN					
Code	Description	Factor	Net Size	Perimeter	Net Totals	Name	Base x	Height x	Width =	Area
GLA2	Second Floor	1.0	2183.3	247.7	2183.3	Second Floor		12.0 x	7.0 =	84.0
								24.1 x	15.6 =	376.4
								22.4 x	4.0 =	89.6
								4.0 x	1.7 =	6.9
							0.5 x	2.2 x	1.1 =	1.2
							0.5 x	3.6 x	1.5 =	2.7
								3.1 x	2.2 =	6.9
							0.5 x	4.8 x	1.7 =	4.1
								44.3 x	20.4 =	903.7
								15.6 x	10.3 =	160.3
								36.5 x	15.0 =	547.5
	Net LIVABLE	cnt	1 (rounded)		2,183	11 total items			(rounded)	2,183

FLOORPLAN SKETCH

Borrower:	File No.: 16538
Property Address: 18507 Square Sail Rd	Case No.:
City: Cornelius	State: NC Zip: 28031
Lender:	

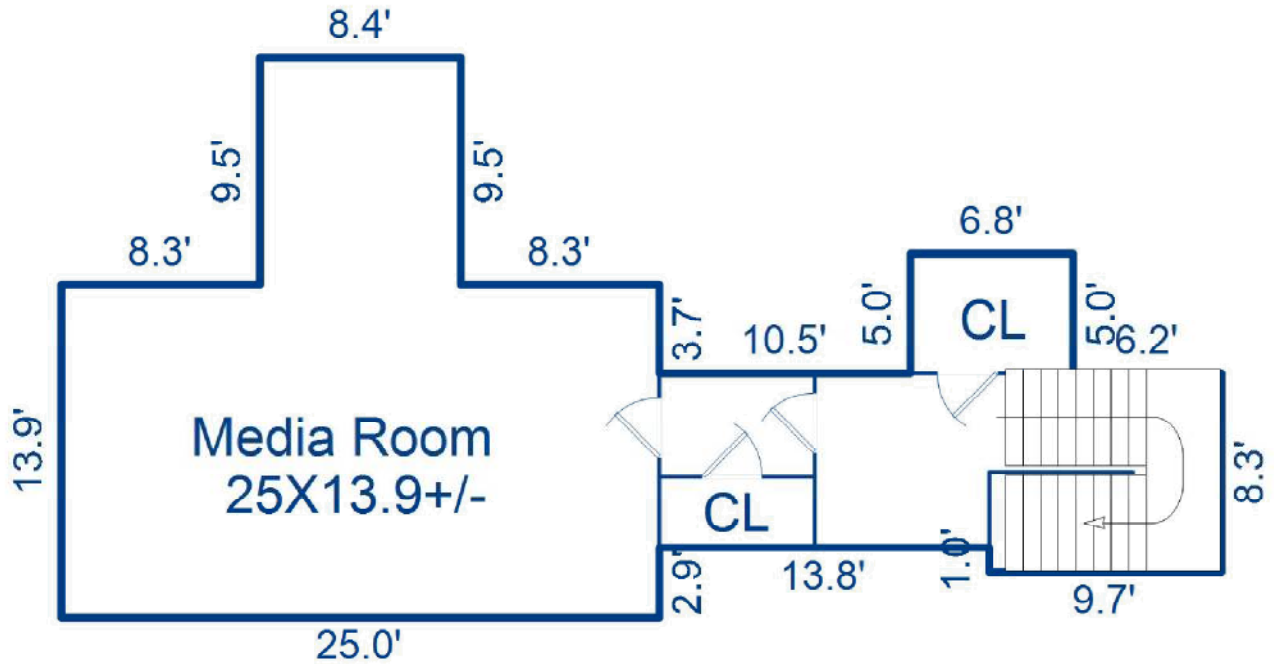

Third Floor
642.6 sf

Sketch by ApexSketch

AREA CALCULATIONS SUMMARY					AREA CALCULATIONS BREAKDOWN					
Code	Description	Factor	Net Size	Perimeter	Net Totals	Name	Base x	Height x	Width =	Area
GLA3	Third Floor	1.0	642.6	155.8	642.6	Third Floor		9.5 x	8.4 =	79.8
								6.8 x	5.0 =	34.0
								9.7 x	8.3 =	80.5
								13.8 x	7.3 =	100.7
								25.0 x	13.9 =	347.5
	Net LIVABLE	cnt	1 (rounded)		643	5 total items			(rounded)	643

DIMENSION LIST ADDENDUM

Borrower:	File No.: 16538
Property Address: 18507 Square Sail Rd	Case No.:
City: Cornelius	State: NC Zip: 28031
Lender:	

GROSS BUILDING AREA (GBA)			<u>5,601</u>
GROSS LIVING AREA (GLA)			<u>4,829</u>
Area(s)	Area	% of GLA	% of GBA
Living	<u>4,829</u>		<u>86.22</u>
Level 1	<u>2,003</u>	<u>41.48</u>	<u>35.76</u>
Level 2	<u>2,183</u>	<u>45.21</u>	<u>38.98</u>
Level 3	<u>643</u>	<u>13.32</u>	<u>11.48</u>
Other			
Basement			
Garage	<u>772</u>		<u>13.78</u>
Other	<u>598</u>		

Area Measurements				Area Type					
Measurements	Factor	Total	Total	Level 1	Level 2	Level 3	Other	Bsmt.	Garage
<u>37.40</u>	x <u>8.60</u>	x <u>1.00</u>	= <u>321.64</u>	<input type="checkbox"/>	<input type="checkbox"/>	<input type="checkbox"/>	<input type="checkbox"/>	<input type="checkbox"/>	<input checked="" type="checkbox"/>
<u>35.00</u>	x <u>4.90</u>	x <u>1.00</u>	= <u>171.50</u>	<input type="checkbox"/>	<input type="checkbox"/>	<input type="checkbox"/>	<input type="checkbox"/>	<input type="checkbox"/>	<input checked="" type="checkbox"/>
<u>31.00</u>	x <u>9.00</u>	x <u>1.00</u>	= <u>279.00</u>	<input type="checkbox"/>	<input type="checkbox"/>	<input type="checkbox"/>	<input type="checkbox"/>	<input type="checkbox"/>	<input checked="" type="checkbox"/>
<u>22.50</u>	x <u>12.50</u>	x <u>1.00</u>	= <u>281.25</u>	<input checked="" type="checkbox"/>	<input type="checkbox"/>	<input type="checkbox"/>	<input type="checkbox"/>	<input type="checkbox"/>	<input type="checkbox"/>
<u>4.90</u>	x <u>2.40</u>	x <u>1.00</u>	= <u>11.76</u>	<input checked="" type="checkbox"/>	<input type="checkbox"/>	<input type="checkbox"/>	<input type="checkbox"/>	<input type="checkbox"/>	<input type="checkbox"/>
<u>9.00</u>	x <u>6.40</u>	x <u>1.00</u>	= <u>57.60</u>	<input checked="" type="checkbox"/>	<input type="checkbox"/>	<input type="checkbox"/>	<input type="checkbox"/>	<input type="checkbox"/>	<input type="checkbox"/>
<u>48.40</u>	x <u>15.60</u>	x <u>1.00</u>	= <u>755.04</u>	<input checked="" type="checkbox"/>	<input type="checkbox"/>	<input type="checkbox"/>	<input type="checkbox"/>	<input type="checkbox"/>	<input type="checkbox"/>
<u>47.10</u>	x <u>0.80</u>	x <u>1.00</u>	= <u>37.68</u>	<input checked="" type="checkbox"/>	<input type="checkbox"/>	<input type="checkbox"/>	<input type="checkbox"/>	<input type="checkbox"/>	<input type="checkbox"/>
<u>33.10</u>	x <u>25.00</u>	x <u>1.00</u>	= <u>827.50</u>	<input checked="" type="checkbox"/>	<input type="checkbox"/>	<input type="checkbox"/>	<input type="checkbox"/>	<input type="checkbox"/>	<input type="checkbox"/>
<u>14.00</u>	x <u>2.30</u>	x <u>1.00</u>	= <u>32.20</u>	<input checked="" type="checkbox"/>	<input type="checkbox"/>	<input type="checkbox"/>	<input type="checkbox"/>	<input type="checkbox"/>	<input type="checkbox"/>
<u>12.00</u>	x <u>7.00</u>	x <u>1.00</u>	= <u>84.00</u>	<input type="checkbox"/>	<input checked="" type="checkbox"/>	<input type="checkbox"/>	<input type="checkbox"/>	<input type="checkbox"/>	<input type="checkbox"/>
<u>24.13</u>	x <u>15.60</u>	x <u>1.00</u>	= <u>376.35</u>	<input type="checkbox"/>	<input checked="" type="checkbox"/>	<input type="checkbox"/>	<input type="checkbox"/>	<input type="checkbox"/>	<input type="checkbox"/>
<u>22.40</u>	x <u>4.00</u>	x <u>1.00</u>	= <u>89.60</u>	<input type="checkbox"/>	<input checked="" type="checkbox"/>	<input type="checkbox"/>	<input type="checkbox"/>	<input type="checkbox"/>	<input type="checkbox"/>
<u>4.00</u>	x <u>1.73</u>	x <u>1.00</u>	= <u>6.90</u>	<input type="checkbox"/>	<input checked="" type="checkbox"/>	<input type="checkbox"/>	<input type="checkbox"/>	<input type="checkbox"/>	<input type="checkbox"/>
<u>2.23</u>	x <u>1.11</u>	x <u>2.00</u>	= <u>1.24</u>	<input type="checkbox"/>	<input checked="" type="checkbox"/>	<input type="checkbox"/>	<input type="checkbox"/>	<input type="checkbox"/>	<input type="checkbox"/>
<u>3.56</u>	x <u>1.54</u>	x <u>2.00</u>	= <u>2.74</u>	<input type="checkbox"/>	<input checked="" type="checkbox"/>	<input type="checkbox"/>	<input type="checkbox"/>	<input type="checkbox"/>	<input type="checkbox"/>
<u>3.08</u>	x <u>2.23</u>	x <u>1.00</u>	= <u>6.86</u>	<input type="checkbox"/>	<input checked="" type="checkbox"/>	<input type="checkbox"/>	<input type="checkbox"/>	<input type="checkbox"/>	<input type="checkbox"/>
<u>4.81</u>	x <u>1.69</u>	x <u>2.00</u>	= <u>4.06</u>	<input type="checkbox"/>	<input checked="" type="checkbox"/>	<input type="checkbox"/>	<input type="checkbox"/>	<input type="checkbox"/>	<input type="checkbox"/>
<u>44.30</u>	x <u>20.40</u>	x <u>1.00</u>	= <u>903.72</u>	<input type="checkbox"/>	<input checked="" type="checkbox"/>	<input type="checkbox"/>	<input type="checkbox"/>	<input type="checkbox"/>	<input type="checkbox"/>
<u>15.60</u>	x <u>10.27</u>	x <u>1.00</u>	= <u>160.29</u>	<input type="checkbox"/>	<input checked="" type="checkbox"/>	<input type="checkbox"/>	<input type="checkbox"/>	<input type="checkbox"/>	<input type="checkbox"/>
<u>36.50</u>	x <u>15.00</u>	x <u>1.00</u>	= <u>547.50</u>	<input type="checkbox"/>	<input checked="" type="checkbox"/>	<input type="checkbox"/>	<input type="checkbox"/>	<input type="checkbox"/>	<input type="checkbox"/>
<u>9.50</u>	x <u>8.40</u>	x <u>1.00</u>	= <u>79.80</u>	<input type="checkbox"/>	<input type="checkbox"/>	<input checked="" type="checkbox"/>	<input type="checkbox"/>	<input type="checkbox"/>	<input type="checkbox"/>
<u>6.80</u>	x <u>5.00</u>	x <u>1.00</u>	= <u>34.00</u>	<input type="checkbox"/>	<input type="checkbox"/>	<input checked="" type="checkbox"/>	<input type="checkbox"/>	<input type="checkbox"/>	<input type="checkbox"/>
<u>9.70</u>	x <u>8.30</u>	x <u>1.00</u>	= <u>80.51</u>	<input type="checkbox"/>	<input type="checkbox"/>	<input checked="" type="checkbox"/>	<input type="checkbox"/>	<input type="checkbox"/>	<input type="checkbox"/>
<u>13.80</u>	x <u>7.30</u>	x <u>1.00</u>	= <u>100.74</u>	<input type="checkbox"/>	<input type="checkbox"/>	<input checked="" type="checkbox"/>	<input type="checkbox"/>	<input type="checkbox"/>	<input type="checkbox"/>
<u>25.00</u>	x <u>13.90</u>	x <u>1.00</u>	= <u>347.50</u>	<input type="checkbox"/>	<input type="checkbox"/>	<input checked="" type="checkbox"/>	<input type="checkbox"/>	<input type="checkbox"/>	<input type="checkbox"/>
	x	x	=	<input type="checkbox"/>	<input type="checkbox"/>	<input type="checkbox"/>	<input type="checkbox"/>	<input type="checkbox"/>	<input type="checkbox"/>
	x	x	=	<input type="checkbox"/>	<input type="checkbox"/>	<input type="checkbox"/>	<input type="checkbox"/>	<input type="checkbox"/>	<input type="checkbox"/>
	x	x	=	<input type="checkbox"/>	<input type="checkbox"/>	<input type="checkbox"/>	<input type="checkbox"/>	<input type="checkbox"/>	<input type="checkbox"/>
	x	x	=	<input type="checkbox"/>	<input type="checkbox"/>	<input type="checkbox"/>	<input type="checkbox"/>	<input type="checkbox"/>	<input type="checkbox"/>
	x	x	=	<input type="checkbox"/>	<input type="checkbox"/>	<input type="checkbox"/>	<input type="checkbox"/>	<input type="checkbox"/>	<input type="checkbox"/>
	x	x	=	<input type="checkbox"/>	<input type="checkbox"/>	<input type="checkbox"/>	<input type="checkbox"/>	<input type="checkbox"/>	<input type="checkbox"/>
	x	x	=	<input type="checkbox"/>	<input type="checkbox"/>	<input type="checkbox"/>	<input type="checkbox"/>	<input type="checkbox"/>	<input type="checkbox"/>
	x	x	=	<input type="checkbox"/>	<input type="checkbox"/>	<input type="checkbox"/>	<input type="checkbox"/>	<input type="checkbox"/>	<input type="checkbox"/>
	x	x	=	<input type="checkbox"/>	<input type="checkbox"/>	<input type="checkbox"/>	<input type="checkbox"/>	<input type="checkbox"/>	<input type="checkbox"/>
	x	x	=	<input type="checkbox"/>	<input type="checkbox"/>	<input type="checkbox"/>	<input type="checkbox"/>	<input type="checkbox"/>	<input type="checkbox"/>
	x	x	=	<input type="checkbox"/>	<input type="checkbox"/>	<input type="checkbox"/>	<input type="checkbox"/>	<input type="checkbox"/>	<input type="checkbox"/>
	x	x	=	<input type="checkbox"/>	<input type="checkbox"/>	<input type="checkbox"/>	<input type="checkbox"/>	<input type="checkbox"/>	<input type="checkbox"/>
	x	x	=	<input type="checkbox"/>	<input type="checkbox"/>	<input type="checkbox"/>	<input type="checkbox"/>	<input type="checkbox"/>	<input type="checkbox"/>
	x	x	=	<input type="checkbox"/>	<input type="checkbox"/>	<input type="checkbox"/>	<input type="checkbox"/>	<input type="checkbox"/>	<input type="checkbox"/>
	x	x	=	<input type="checkbox"/>	<input type="checkbox"/>	<input type="checkbox"/>	<input type="checkbox"/>	<input type="checkbox"/>	<input type="checkbox"/>
	x	x	=	<input type="checkbox"/>	<input type="checkbox"/>	<input type="checkbox"/>	<input type="checkbox"/>	<input type="checkbox"/>	<input type="checkbox"/>
	x	x	=	<input type="checkbox"/>	<input type="checkbox"/>	<input type="checkbox"/>	<input type="checkbox"/>	<input type="checkbox"/>	<input type="checkbox"/>
	x	x	=	<input type="checkbox"/>	<input type="checkbox"/>	<input type="checkbox"/>	<input type="checkbox"/>	<input type="checkbox"/>	<input type="checkbox"/>
	x	x	=	<input type="checkbox"/>	<input type="checkbox"/>	<input type="checkbox"/>	<input type="checkbox"/>	<input type="checkbox"/>	<input type="checkbox"/>
	x	x	=	<input type="checkbox"/>	<input type="checkbox"/>	<input type="checkbox"/>	<input type="checkbox"/>	<input type="checkbox"/>	<input type="checkbox"/>
	x	x	=	<input type="checkbox"/>	<input type="checkbox"/>	<input type="checkbox"/>	<input type="checkbox"/>	<input type="checkbox"/>	<input type="checkbox"/>
	x	x	=	<input type="checkbox"/>	<input type="checkbox"/>	<input type="checkbox"/>	<input type="checkbox"/>	<input type="checkbox"/>	<input type="checkbox"/>
	x	x	=	<input type="checkbox"/>	<input type="checkbox"/>	<input type="checkbox"/>	<input type="checkbox"/>	<input type="checkbox"/>	<input type="checkbox"/>
	x	x	=	<input type="checkbox"/>	<input type="checkbox"/>	<input type="checkbox"/>	<input type="checkbox"/>	<input type="checkbox"/>	<input type="checkbox"/>
	x	x	=	<input type="checkbox"/>	<input type="checkbox"/>	<input type="checkbox"/>	<input type="checkbox"/>	<input type="checkbox"/>	<input type="checkbox"/>
	x	x	=	<input type="checkbox"/>	<input type="checkbox"/>	<input type="checkbox"/>	<input type="checkbox"/>	<input type="checkbox"/>	<input type="checkbox"/>
	x	x	=	<input type="checkbox"/>	<input type="checkbox"/>	<input type="checkbox"/>	<input type="checkbox"/>	<input type="checkbox"/>	<input type="checkbox"/>
	x	x	=	<input type="checkbox"/>	<input type="checkbox"/>	<input type="checkbox"/>	<input type="checkbox"/>	<input type="checkbox"/>	<input type="checkbox"/>
	x	x	=	<input type="checkbox"/>	<input type="checkbox"/>	<input type="checkbox"/>	<input type="checkbox"/>	<input type="checkbox"/>	<input type="checkbox"/>
	x	x	=	<input type="checkbox"/>	<input type="checkbox"/>	<input type="checkbox"/>	<input type="checkbox"/>	<input type="checkbox"/>	<input type="checkbox"/>
	x	x	=	<input type="checkbox"/>	<input type="checkbox"/>	<input type="checkbox"/>	<input type="checkbox"/>	<input type="checkbox"/>	<input type="checkbox"/>
	x	x	=	<input type="checkbox"/>	<input type="checkbox"/>	<input type="checkbox"/>	<input type="checkbox"/>	<input type="checkbox"/>	<input type="checkbox"/>
	x	x	=	<input type="checkbox"/>	<input type="checkbox"/>	<input type="checkbox"/>	<input type="checkbox"/>	<input type="checkbox"/>	<input type="checkbox"/>
	x	x	=	<input type="checkbox"/>	<input type="checkbox"/>	<input type="checkbox"/>	<input type="checkbox"/>	<input type="checkbox"/>	<input type="checkbox"/>
	x	x	=	<input type="checkbox"/>	<input type="checkbox"/>	<input type="checkbox"/>	<input type="checkbox"/>	<input type="checkbox"/>	<input type="checkbox"/>
	x	x	=	<input type="checkbox"/>	<input type="checkbox"/>	<input type="checkbox"/>	<input type="checkbox"/>	<input type="checkbox"/>	<input type="checkbox"/>
	x	x	=	<input type="checkbox"/>	<input type="checkbox"/>	<input type="checkbox"/>	<input type="checkbox"/>	<input type="checkbox"/>	<input type="checkbox"/>
	x	x	=	<input type="checkbox"/>	<input type="checkbox"/>	<input type="checkbox"/>	<input type="checkbox"/>	<input type="checkbox"/>	<input type="checkbox"/>
	x	x	=	<input type="checkbox"/>	<input type="checkbox"/>	<input type="checkbox"/>	<input type="checkbox"/>	<input type="checkbox"/>	<input type="checkbox"/>
	x	x	=	<input type="checkbox"/>	<input type="checkbox"/>	<input type="checkbox"/>	<input type="checkbox"/>	<input type="checkbox"/>	<input type="checkbox"/>
	x	x	=	<input type="checkbox"/>	<input type="checkbox"/>	<input type="checkbox"/>	<input type="checkbox"/>	<input type="checkbox"/>	<input type="checkbox"/>