

Print Now

Parcel ID: 000009 000028 001-14 (CARD 1 of 1)
 Owner: BOUTIN EUGENE, TRUSTEE
 BOUTIN CATHERINE, TRUSTEE
 Location: 0082 CEDAR CREST LANE
 Acres: 3.234

General

Valuation		Listing History	
Building Value:	\$815,000	List Date	Lister
Features:	\$5,000	07/24/2019	DMVM
Taxable Land:	\$264,000	02/22/2019	INSP
Card Value:	\$1,084,000	07/28/2014	DMVM
Parcel Value:	\$1,084,000	07/16/2014	INSP
		03/27/2012	DMPM

Notes: GRAY;1/07 INGRD SPRINKLER SYS/HSE; (2) GEN; 7/19 NOH/EXT=GOOD;CORR'D FPL;ABOVE AVG SIDING=VINYL SHAKES;STONE FPL CHIMNEY;

Sales

Sale Date	Sale Type	Qualified	Sale Price	Grantor	Book	Page
04/27/2018	IMPROVED	NO - FAMILY/RELAT GRNTR/E	\$1	BOUTIN EUGENE W,	5908	2422
03/21/2018	IMPROVED	NO - FAMILY/RELAT GRNTR/E	\$1	BOUTIN EUGENE W, TRUSTEE	5899	2495
09/10/2015	IMPROVED	NO - FAMILY/RELAT GRNTR/E	\$1	BOUTIN EUGENE W	5652	2203
02/01/2007	IMPROVED	NO - IMPRVMT U/C AT ASMT	\$745,000	PEAK DEVELOPMENT CORP	4762	0034
06/01/2005	VACANT	YES	\$170,000	TENN SYLVIA	4491	921
08/08/2001	VACANT	NO - ABUTTER SALE	\$1	UNKNOWN	??	??

Land

Size: 3.234 Ac. **Site:** VERY GOOD
Zone: 02 - RESIDENTIAL 1 & 2 **Driveway:** PAVED
Neighborhood: AVG +30 **Road:** PAVED
Land Use: 1F RES **Taxable Value:** \$264,000

Land Type	Units	Base Rate	NC	Adj	Site	Road	Dway	Topo	Cond	Ad Valorem	SPI	R	Tax Value	Notes
1F RES	2.000 AC	190,000	H	130	110	100	100	95 MILD	100	258,100	0	N	258,100	
1F RES	1.234 AC	5,000	X	100	0	0	0	95 MILD	100	5,900	0	N	5,900	

Building

2.00 STORY FRAME COLONIAL Built In 2006

Roof: GABLE OR HIP ASPHALT **Bedrooms:** 4 **Quality:** EXC
Exterior: ABOVE AVG VINYL SIDING **Bathrooms:** 3.0 **Size Adj.** 0.8961
Interior: DRYWALL **Extra Kitchens:** 0 **Base Rate:** 146.00
Flooring: HARDWOOD **Fireplaces:** 0 **Building Rate:** 1.4262
Generators: 2 **Sq. Foot Cost:** 208.22
AC: YES **Effective Area:** 4,448
100% **Gross Living Area:** 3,586

Heat: OIL

FA DUCTED

Cost New:

\$926,163

Depreciation						
Normal	Physical	Functional	Economic	Temporary	Total Dpr.	Assessment
GOOD 12%	0%	0%	0%	0%	12%	\$815,000

Features

Feature Type	Units	Length x Width	Size Adj	Rate	Cond	Value	Notes
FIREPLACE 1-CUST	1		100	5000.00	100	\$5,000	
Total:						\$5,000	

Photo



Sketch

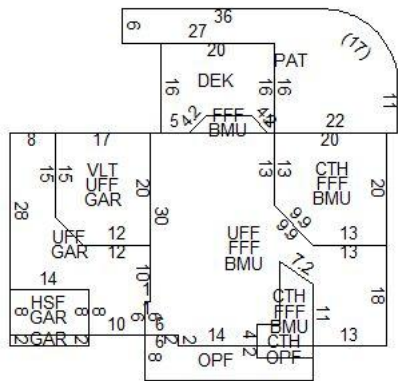

Code	Description	Area	Eff Area	GL Area
CTH	CATHEDRAL CEILING	490	49	0
FFF	FST FLR FIN	1,625	1,625	1,625
BMU	BSMNT UNFINISHED	1,625	244	0
GAR	GARAGE ATTACHED	922	415	0
VLT	VAULTED	328	16	0
UFF	UPPER FLR FIN	1,905	1,905	1,905
OPF	OPEN PORCH	192	48	0
DEK	DECK/ENTRANCE	287	29	0
PAT	PATIO	609	61	0
HSF	1/2 STRY FIN	112	56	56
Totals			4,448	3,586

Printed on 09-10-24