

PRIOR TO FOUNDATION INSPECTION BY THE CITY, THE ILS OF RECORD SHALL PROVIDE A WRITTEN CERTIFICATION THAT ALL BUILDING SETBACKS ARE PER THE APPROVED PLANS

DISPOSITION AND TREATMENT OF STORM WATER WILL COMPLY WITH THE NATIONAL POLLUTION DISCHARGE ELIMINATION SYSTEM (NPDES) STANDARDS AND IMPLEMENTATION STANDARDS ESTABLISHED BY THE SANTA CLARA VALLEY URBAN RUNOFF POLLUTION PREVENTION PROGRAM

NOTE: PROJECT IS NOT IN A WILDLIFE-URBAN INTERFACE (WUI) AREA

	SETBACKS			
	REQUIRED	HOUSE EXISTING	HOUSE PROPOSED	ADU
FRONT	30'-0"	21'-8"	21'-8"	N/A
LEFT	25'-0"	29'-4"	25'-0"	24'-0"
RIGHT	20'-0"	43'-1"	44'-2"	21'-5"
REAR	20'-0"	16'-4"	15'-3"	21'-0"

	HEIGHT TABLE	
	ADU	HOUSE
LOWEST POINT	293.41'	300.41'
HIGHEST POINT	294.83'	301.21'
AVERAGE	294.25'	300.94'
BUILDING HEIGHT	315.92'	324.52'
	21'-8"	23'-1"

AREA SCHEDULE

LOT AREA (GROSS-NET)	41,115 S.F.		
SLOPE AT BLDG. EDGE	2%		
AVERAGE SLOPE (SEE TOPO)	11.4%		
LIVABLE AREA	EXISTING	PROPOSED	TOTAL
MAIN FLOOR	9,029 S.F.	1,045 S.F.	4,084 S.F.
ADU	0 S.F.	800 S.F.	800 S.F.
TOTAL	3,029 S.F.	1,845 S.F.	4,884 S.F.
GARAGE	424 S.F.	238 S.F.	862 S.F.
COVERED PORCH	45 S.F.		
COVERED TERRACE	491 S.F.		
FLOOR AREA	ALLOWED (4,000+35-845)	5,190 S.F.	
	EXISTING	3,443 S.F.	
	PROPOSED	4,146 S.F.	
SITE COVERAGE (95%)	ALLOWED	14,421 S.F.	
	EXISTING SURFACES	4,032 S.F.	
	HOUSE FOOTPRINT	3,046 S.F.	
	DRIVEWAY	3,340 S.F.	
	DECKS/PATIOS	515 S.F.	
	POOL/SHEDS	13,023 S.F.	
	PROPOSED		

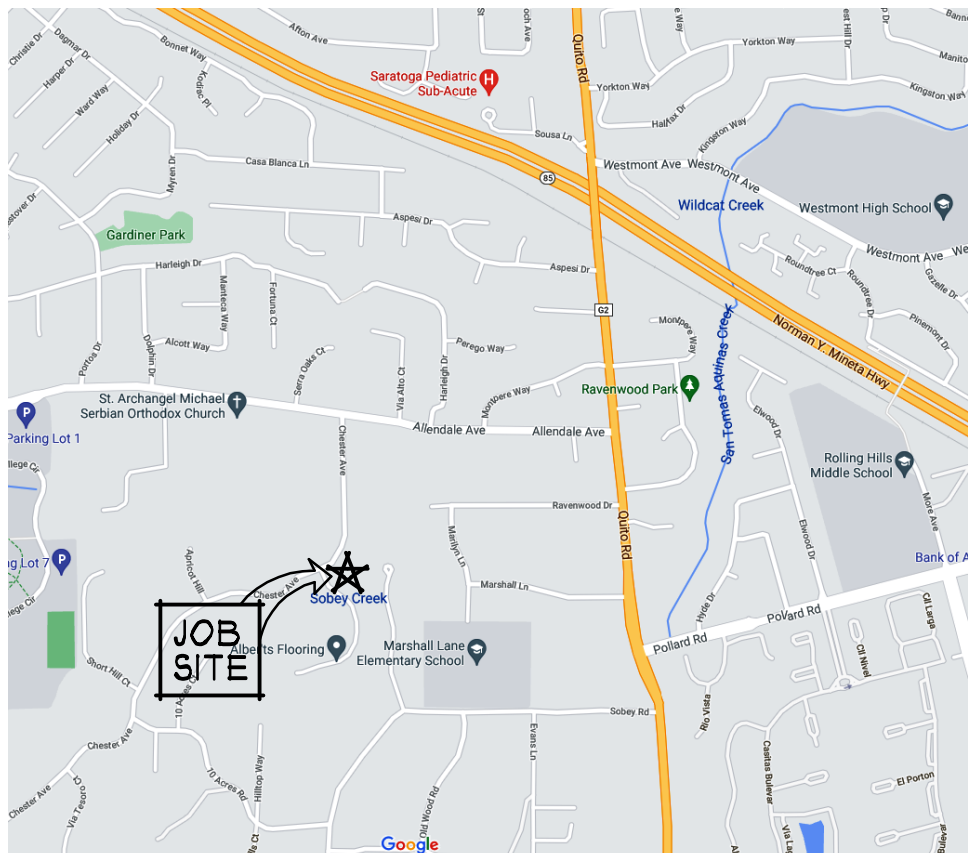

INDEX OF DRAWINGS

- A1 SITE PLAN VICINITY PLAN
- A2 EXISTING FLOOR PLAN AREA DIAGRAMS
- A3 PROPOSED FLOOR PLAN
- A4 ROOF PLAN
- A5 ADU FLOOR PLAN ADU ROOF PLAN ADU BUILDING SECTIONS
- A6 EXTERIOR ELEVATIONS
- A7 EXTERIOR ELEVATIONS
- A8 EXISTING EXTERIOR ELEVATIONS
- A9 ADU EXTERIOR ELEVATIONS
- A10 BUILDING SECTIONS
- A11 BUILDING SECTIONS

PROJECT INFO

OWNER: STUART WELLS
14020 ARCADIA PALMS DRIVE
SARATOGA, CA 95010

JOB ADDRESS: 14020 ARCADIA PALMS DRIVE
SARATOGA, CA 95010

ZONING: RI-40.000

YEAR BUILT: 1912

BUILDING OCCUPANCY GROUP(S): R-3/U

TYPE(S) OF CONSTRUCTION: V-B

OCCUPANCY CATEGORY: II

A.P.N.: 391-01-038

ARCHITECT: RH ASSOCIATES, ARCHITECTS
1010 COMBIE RD, SUITE 210
AUBURN, CA 95602
CONTACT: J. STEVE COLLOM
(530) 248-3055
steve.collo@gmail.com

CIVIL ENGINEER: NNR ENGINEERING
535 WEYBRIDGE DRIVE
SAN JOSE, CA 95123
CONTACT: NADIM RAFOUL
(408) 348-1813
nnrengineering@yahoo.com

GEOTECHNICAL ENGINEER: BAGG ENGINEERS
138 CHARCOT AVENUE
SAN JOSE, CA 95131
CONTACT: MICHAEL MATUSICH, PE, GE
(450) 852-9133
info@baggengineers.com

PROJECT DESCRIPTION: ADDITION TO AN EXISTING ONE-STORY RESIDENCE WITH ATTACHED GARAGE AND A NEW DETACHED ADDITIONAL DWELLING UNIT. NO TREES ARE PROPOSED TO BE REMOVED.

ASSOCIATES ARCHITECTS
11010 COMBIE RD, STE. 210
AUBURN, CA 95602
530-268-3055
J. STEVE COLLOM
rharchitects.com
rhassoc@rhglobal.net

LICENSED ARCHITECT
J. STEVE COLLOM
No. C 11982
Exp. 10-21
STATE OF CALIFORNIA

A PROPOSED REMODEL & ADDITION FOR:
MR. STUART WELLS
14020 ARCADIA PALMS DRIVE SARATOGA, CALIFORNIA

drawings
SITE PLAN

revisions

project number
2576

date
8/1/23

sheet number
A1

SITE PLAN

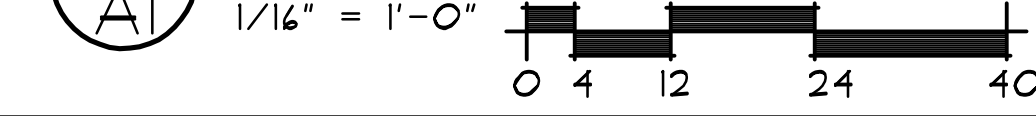

VICINITY MAP



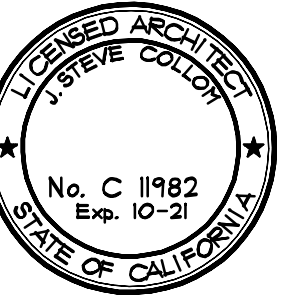

drawings
 EXISTING
 FLOOR PLAN
 AREA
 DIAGRAMS

revisions

project number
 2576

date
 8/1/23

sheet number

A2

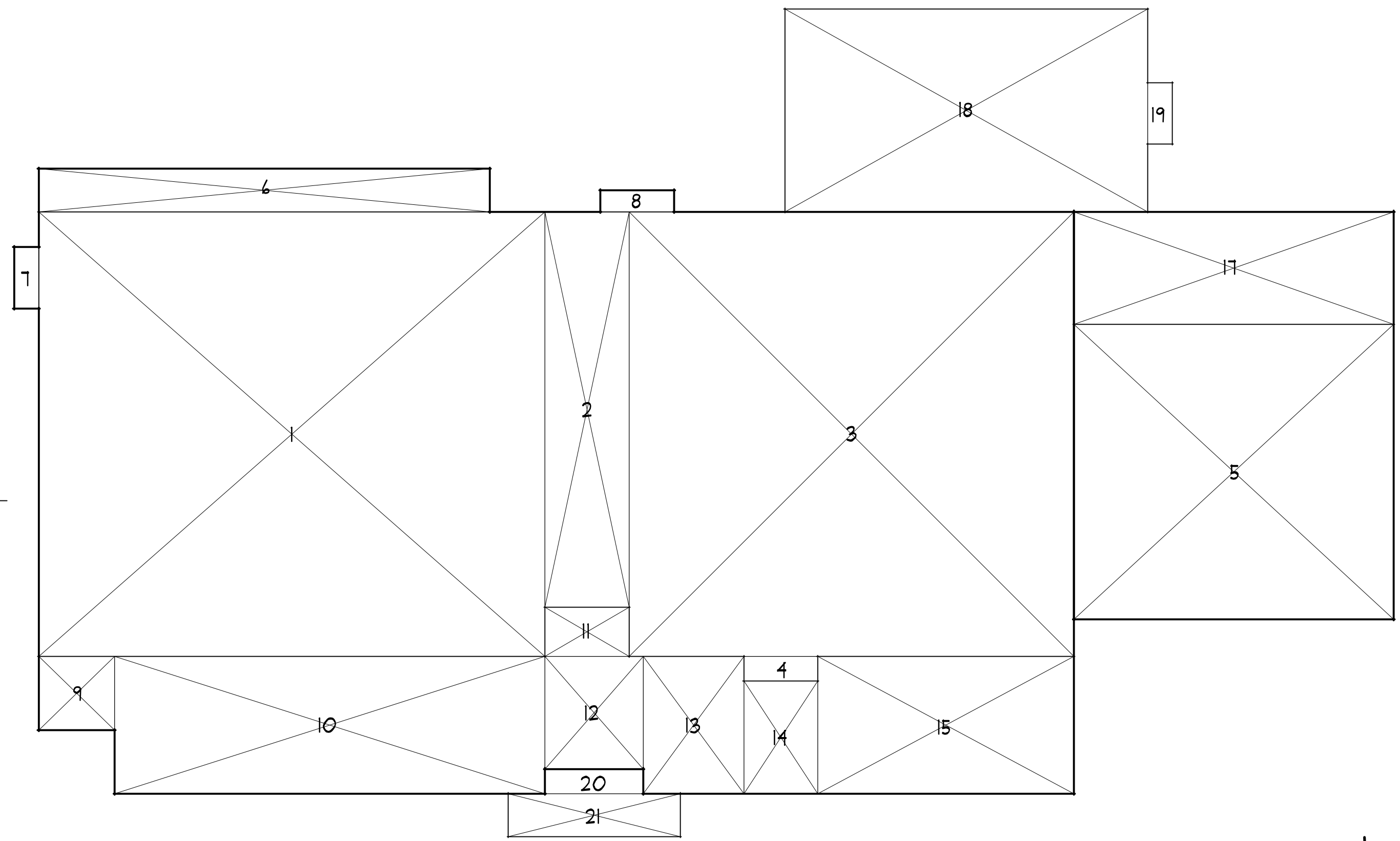
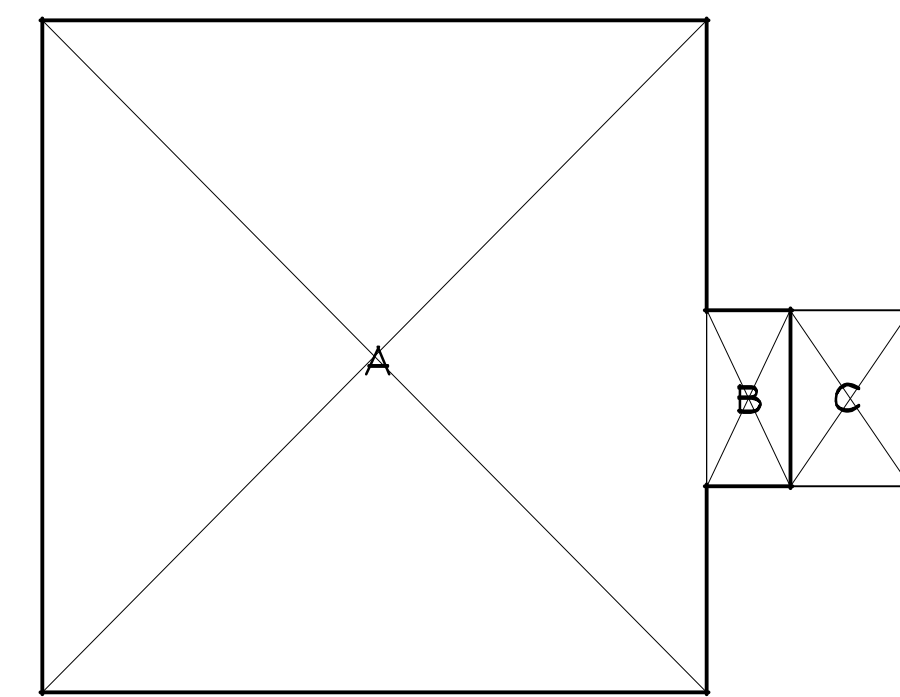

AREA CALCULATIONS

EXISTING LIVABLE AREA		NEW GARAGE	
4.00 x 36.11	146.44	11 24.00 x 9.11	238
4.83 x 32.11	155.08	COVERED PORCH	
36.11 x 36.11	1308	18 24.50 x 16.50	401
4.00 x 2.00	8	19 2.00 x 5.00	10
	TOTAL 3,024	20 8.00 x 5.00	40
		21 14.00 x 3.50	49
			TOTAL 542
EXISTING GARAGE		ADU LIVABLE AREA	
5 24.00 x 24.00	424	A 21.11 x 28.00	115
NEW LIVABLE AREA		B 3.50 x 1.33	24
4.00 x 3.50	14		TOTAL 800
4.00 x 5.00	20	ADU COVERED PORCH	
4.11 x 4.00	16.44	C 5.00 x 1.33	31
35.00 x 4.00	140		
4.83 x 4.00	19.32		
8.00 x 4.11	32.88		
8.11 x 4.11	33.44		
4.00 x 4.11	16.44		
20.83 x 4.11	85.61		
	TOTAL 1,054		

2 AREA DIAGRAMS
 1/8" = 1'-0"

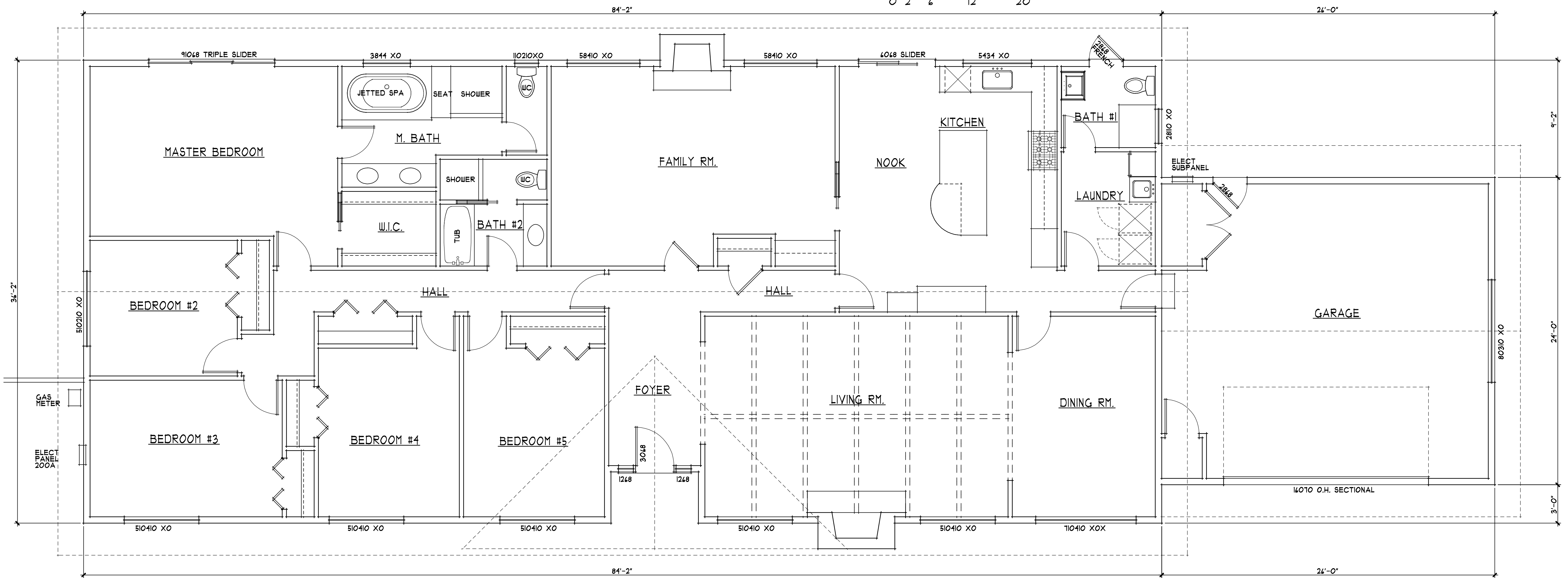

1 EXISTING FLOOR PLAN
 1/4" = 1'-0"

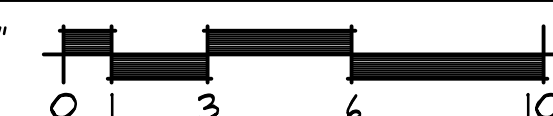

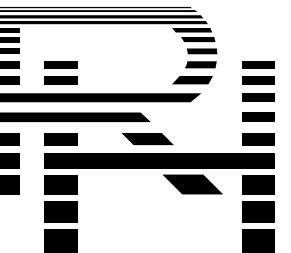

ASSOCIATES
ARCHITECTS
11010 combe rd. ste. 210
AUBURN, CA 95602
530-268-3055
J. STEVE COLLOM
rhaarchitects.com
rhaassoc@abglobal.net

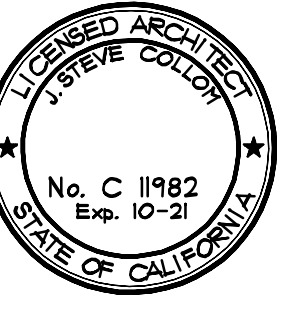

A PROPOSED REMODEL & ADDITION FOR:
MR. STUART WELLS
14020 ARCADIA PALMS DRIVE SARATOGA, CALIFORNIA

drawings
PROPOSED
FLOOR PLAN

revisions

project number
2576

date
8/1/23

sheet number

A3

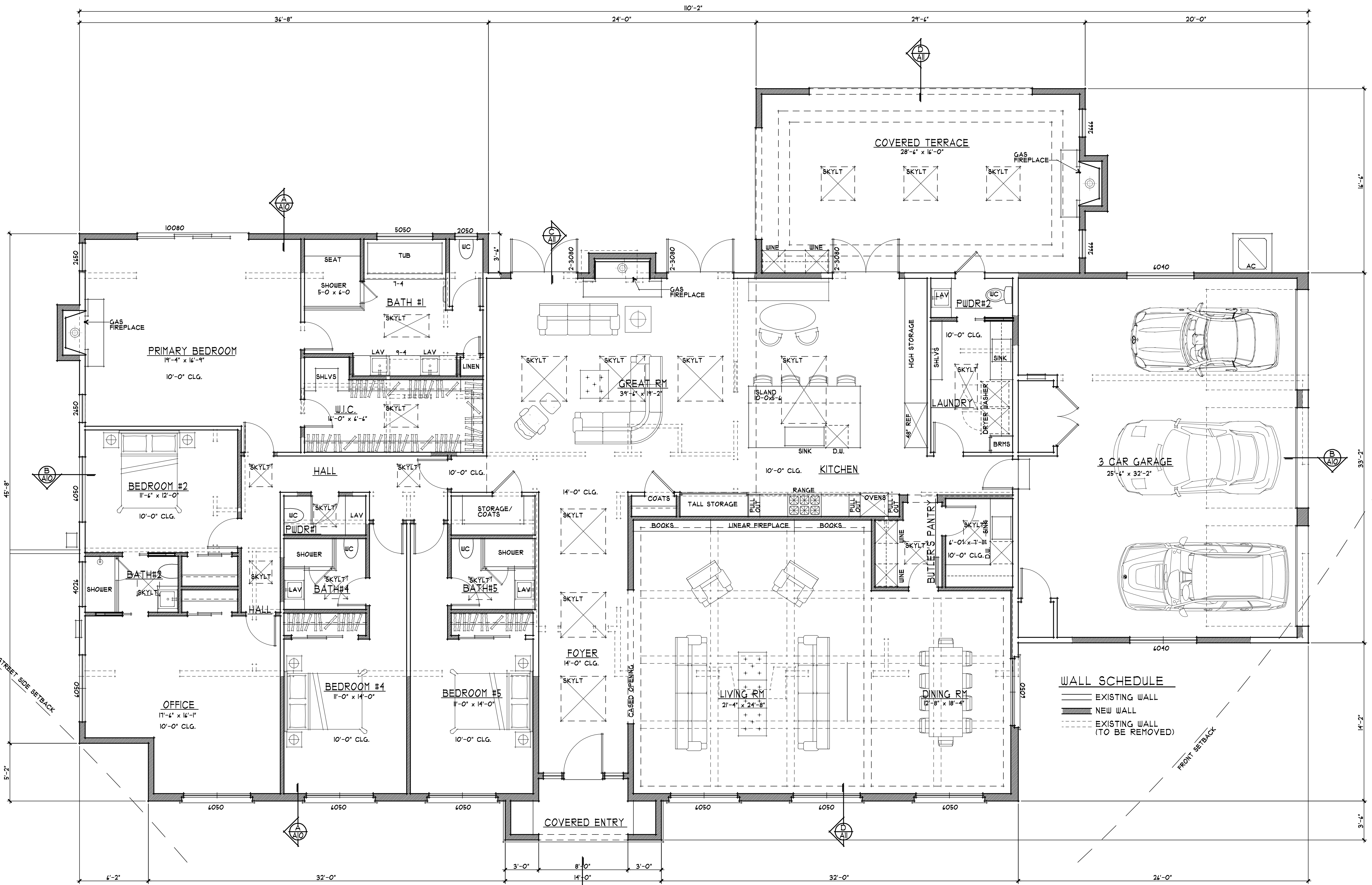

PROPOSED FLOOR PLAN
1/4" = 1'-0"
0 1 3 6 10

MAIN FLOOR 4,076 S.F.
GARAGE 842 S.F.
COVERED PORCHES 562 S.F.



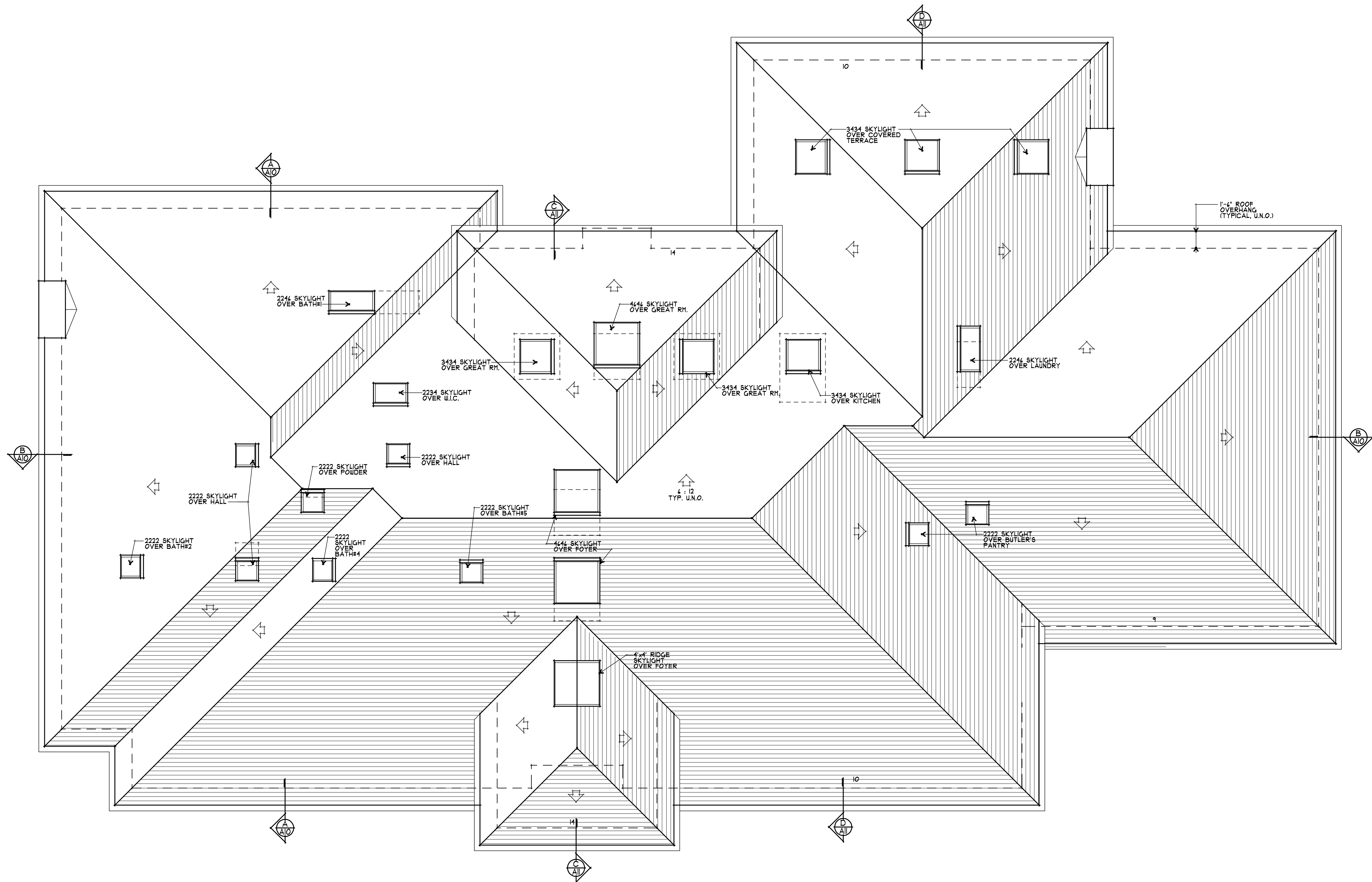

PROPOSED ROOF PLAN
 1/4" = 1'-0"



NORTH

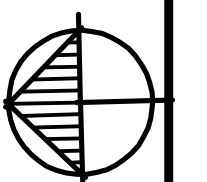

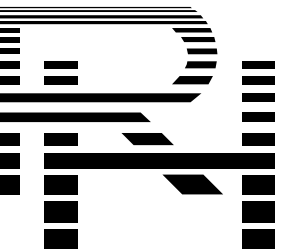

ASSOCIATES
ARCHITECTS
11010 combe rd. ste. 210
AUBURN, CA 95602
530-268-3055
J. STEVE COLLOM
rhaarchitects.com
rhaassoc@abglobal.net

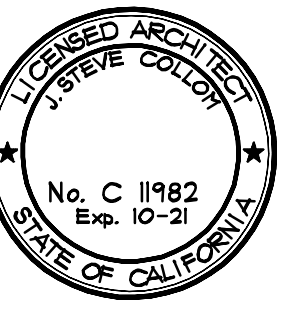

A PROPOSED REMODEL & ADDITION FOR:
MR. STUART WELLS
14020 ARCADIA PALMS DRIVE SARATOGA, CALIFORNIA

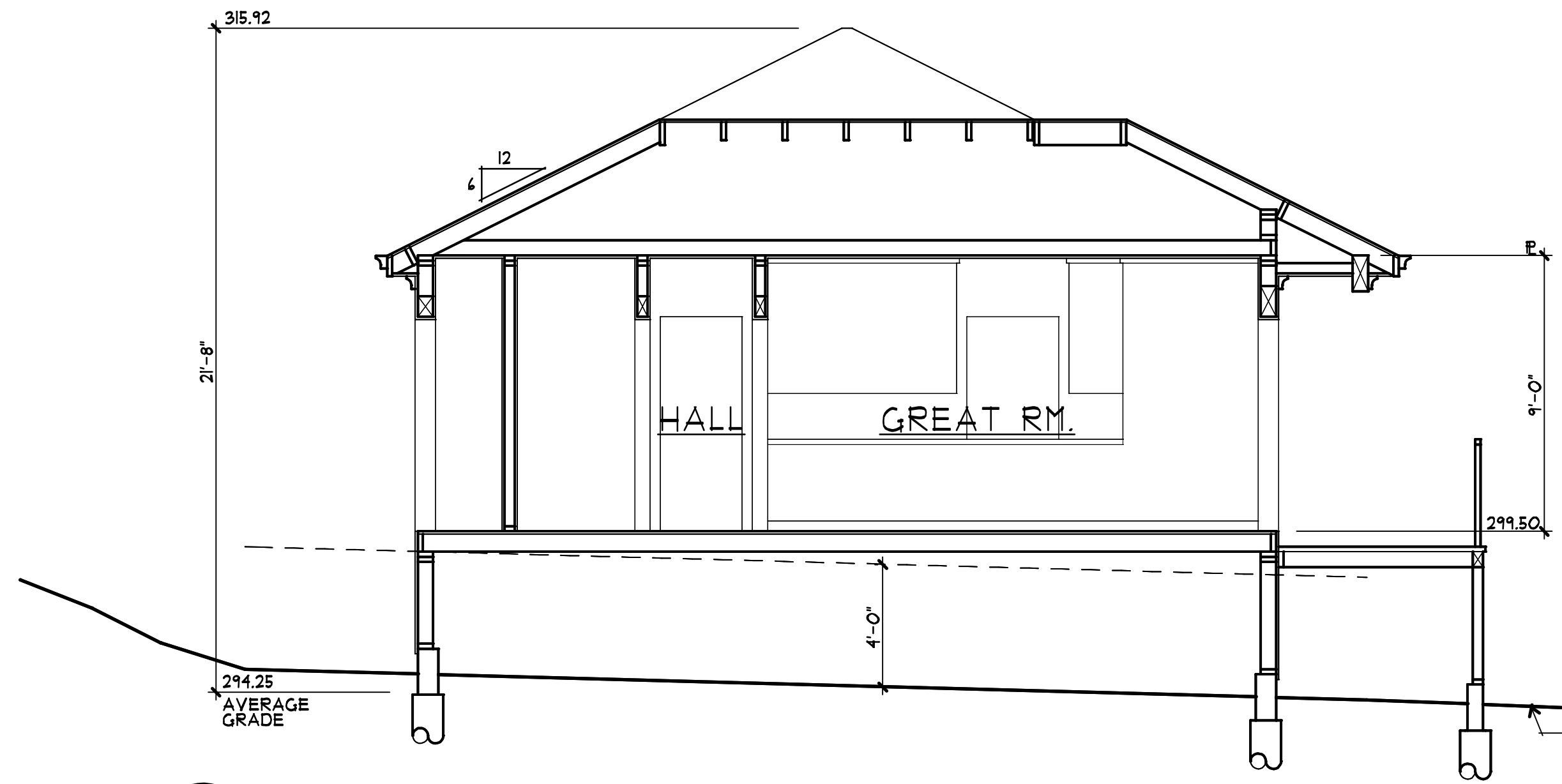

A A.D.U. BUILDING SECTION
A5 1/4" = 1'-0"
0 1 3 6 10

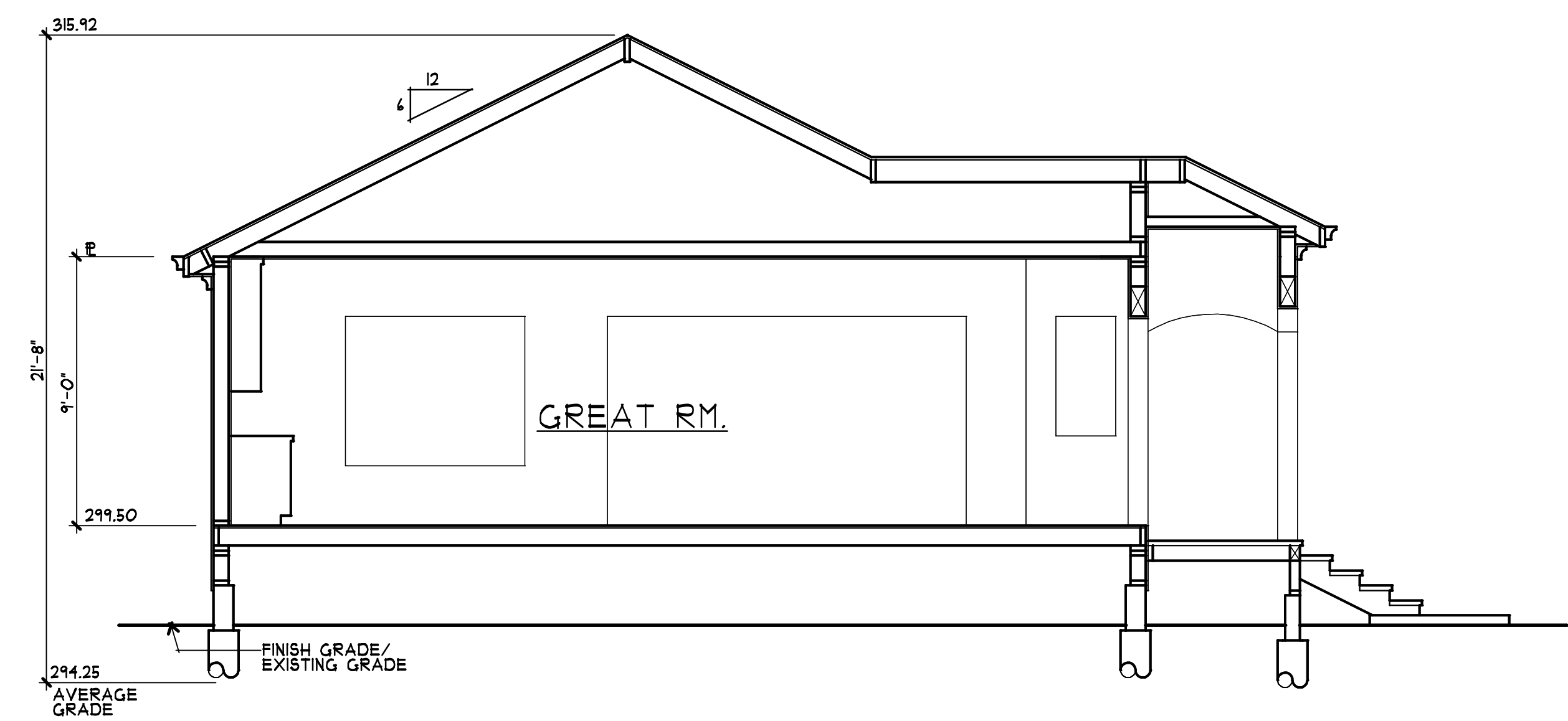

B A.D.U. BUILDING SECTION
A5 1/4" = 1'-0"
0 1 3 6 10

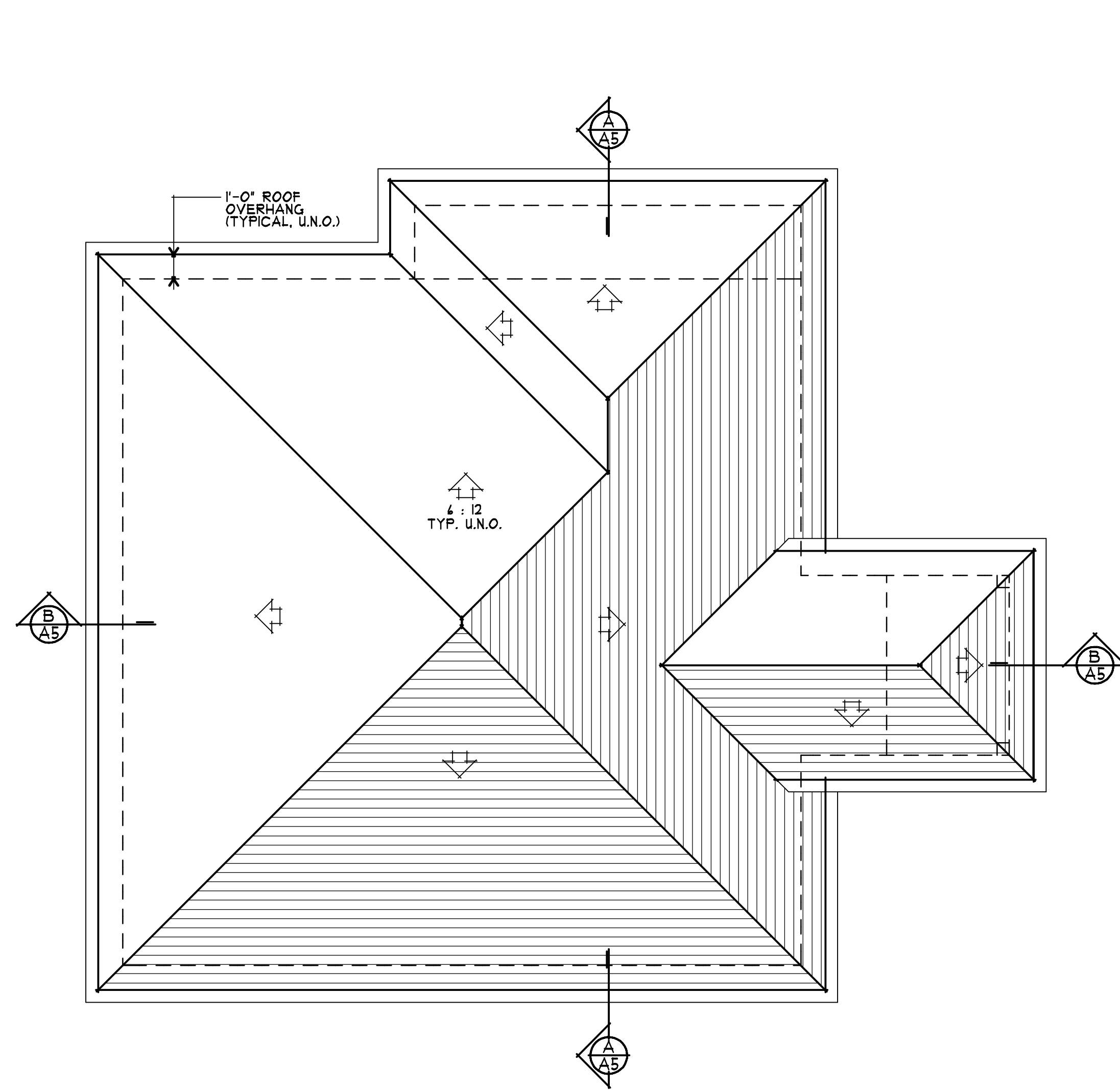

2 A.D.U. ROOF PLAN
A5 1/16" = 1'-0"
0 4 12 24 40

NORTH

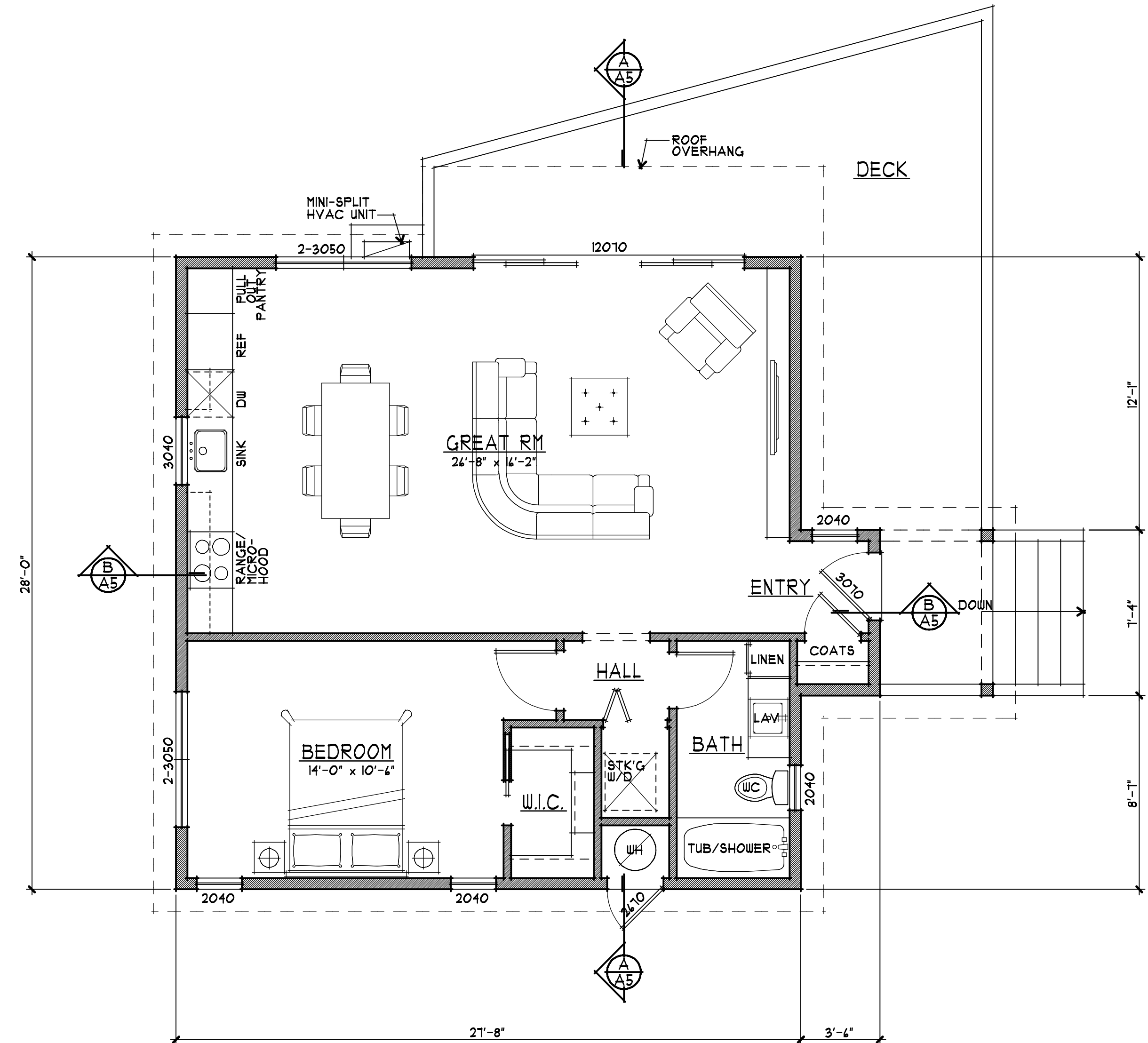
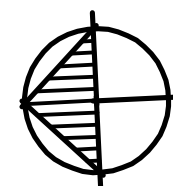

1 A.D.U. FLOOR PLAN
A5 1/16" = 1'-0"
0 4 12 24 40

NORTH

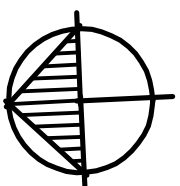

drawings	A.D.U. FLOOR PLAN
revisions	
project number	2576
date	8/1/23
sheet number	A5

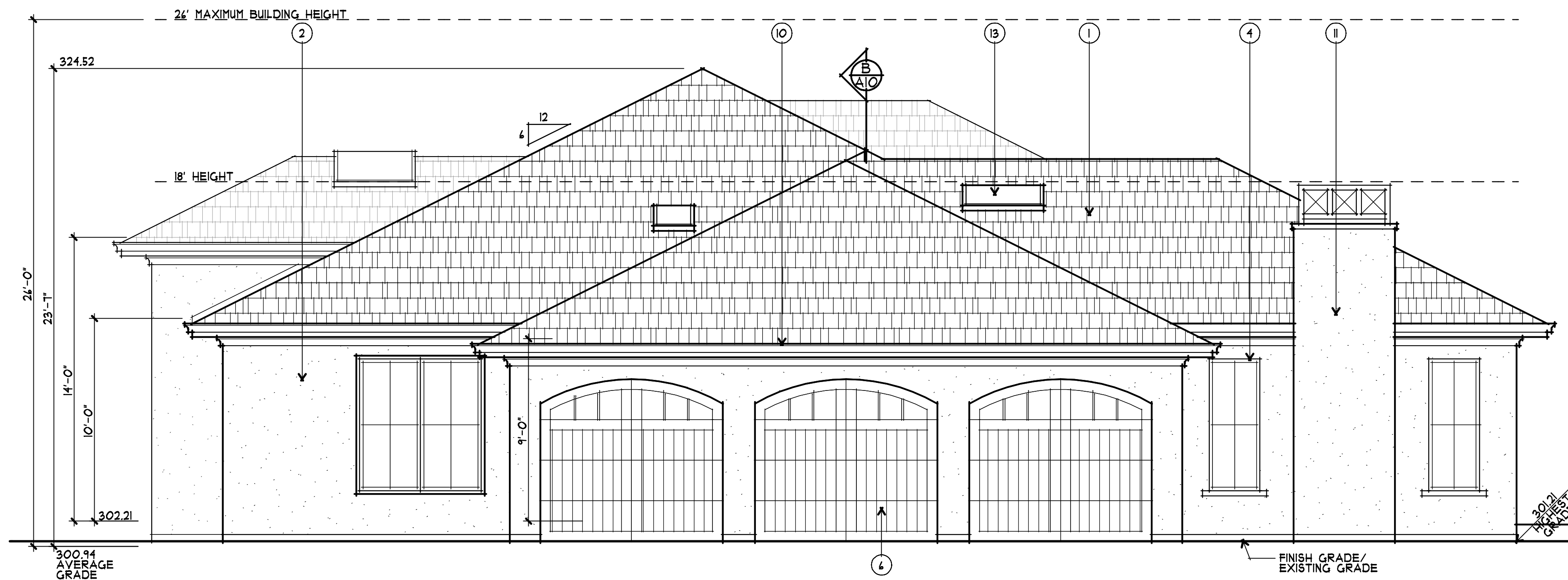

1 RIGHT (SOUTH) ELEVATION
A6 1/4" = 1'-0"

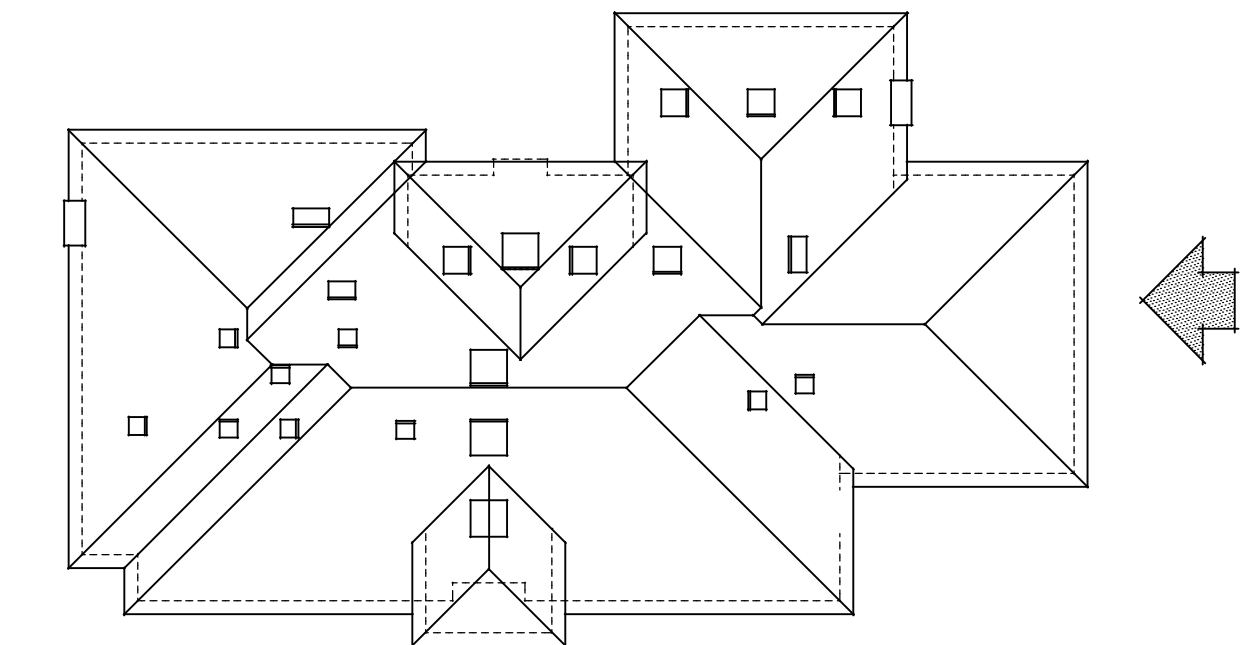

EXTERIOR FINISH SCHEDULE		
LOCATION	KEYNOTE	MATERIAL/COLOR
ROOF	1	SYNTHETIC SLATE ROOF TILE
WALLS	2	STUCCO WITH SMOOTH TROWEL FINISH
	3	
WINDOWS	4	ALUMINUM CLAD WOOD WINDOWS
DOORS	5	WOOD ENTRY DOOR W/ GLASS & SIDELITES
	6	CARRIAGE-STYLE, OVERHEAD SECTIONAL GARAGE DOOR W/ LITES
	7	WOOD FRENCH DOOR(S)
	8	WOOD SLIDING DOOR(S)
RAILINGS	9	TEMPERED GLASS
GUTTERS & DOWNSPOUTS	10	G.I. SHAPED GUTTER W/ RECTANGULAR DOWNSPOUTS
CHIMNEY	11	STUCCO WITH SMOOTH TROWEL FINISH
FLASHING	12	G.I. FLASHING - PAINT
SKYLIGHTS	13	CURB-MOUNTED BY VELUX OR EQ.

ASSOCIATES ARCHITECTS
 11010 combe rd. ste. 210
 AUBURN, CA 95602
 530-268-3055
 J. STEVE COLLOM
 rhaarchitects.com
 rhaassoc@abglobal.net

LICENSED ARCHITECT
 J. STEVE COLLOM
 No. C 11982
 Exp. 10-21
 STATE OF CALIFORNIA

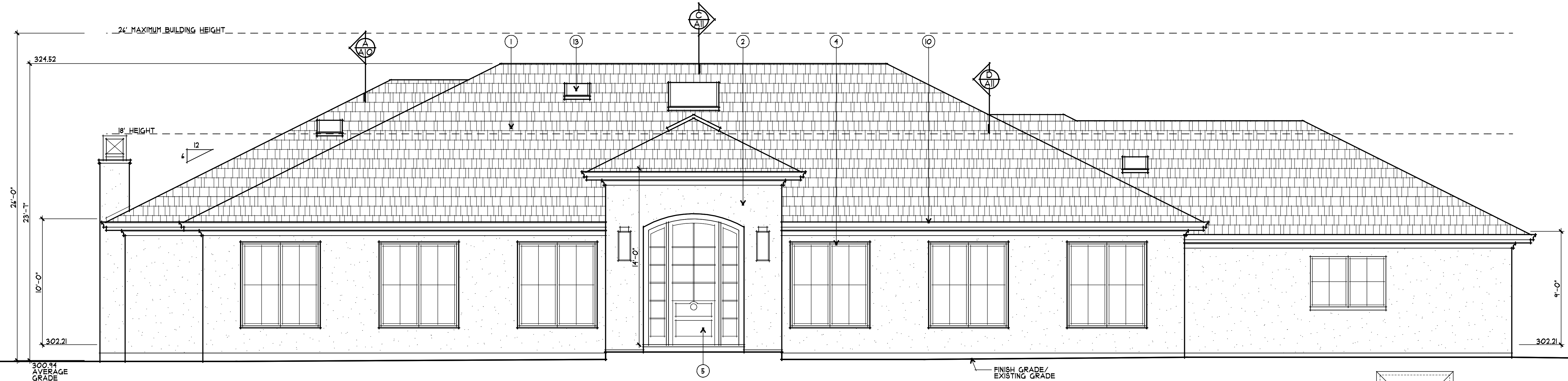

2 FRONT (WEST) ELEVATION
A6 1/4" = 1'-0"

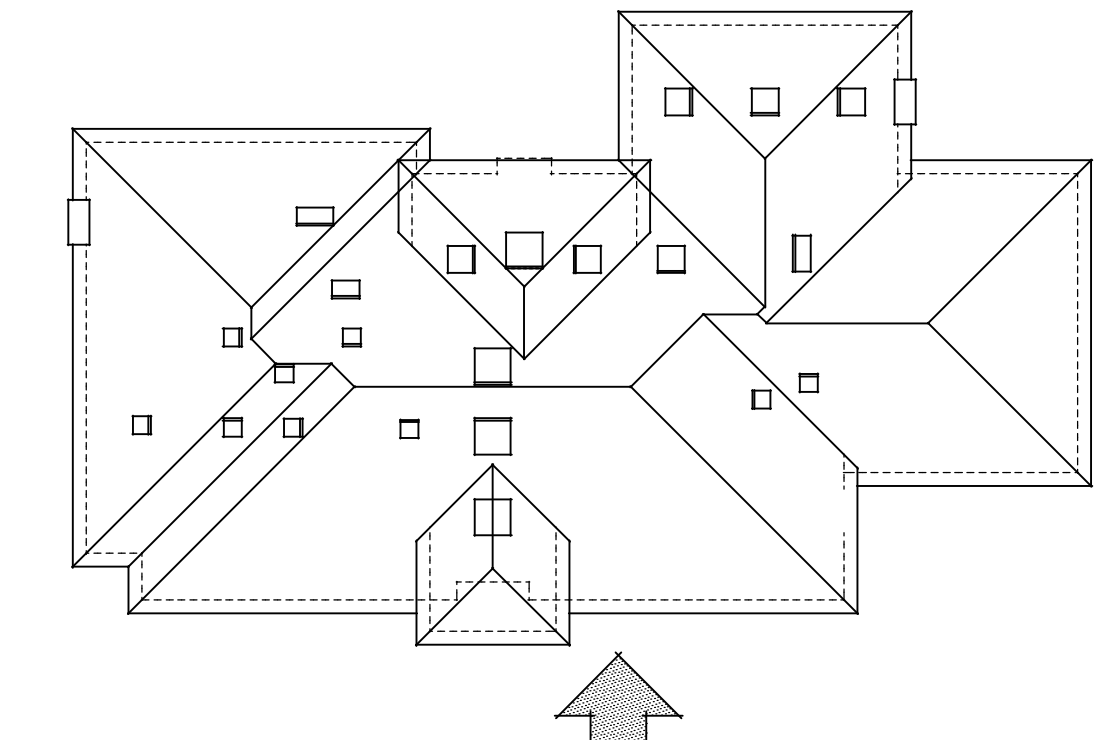

A PROPOSED REMODEL & ADDITION FOR:
MR. STUART WELLS
 14020 ARCADIA PALMS DRIVE SARATOGA, CALIFORNIA

drawings	EXTERIOR ELEVATIONS
revisions	
project number	2576
date	8/1/23
sheet number	A6

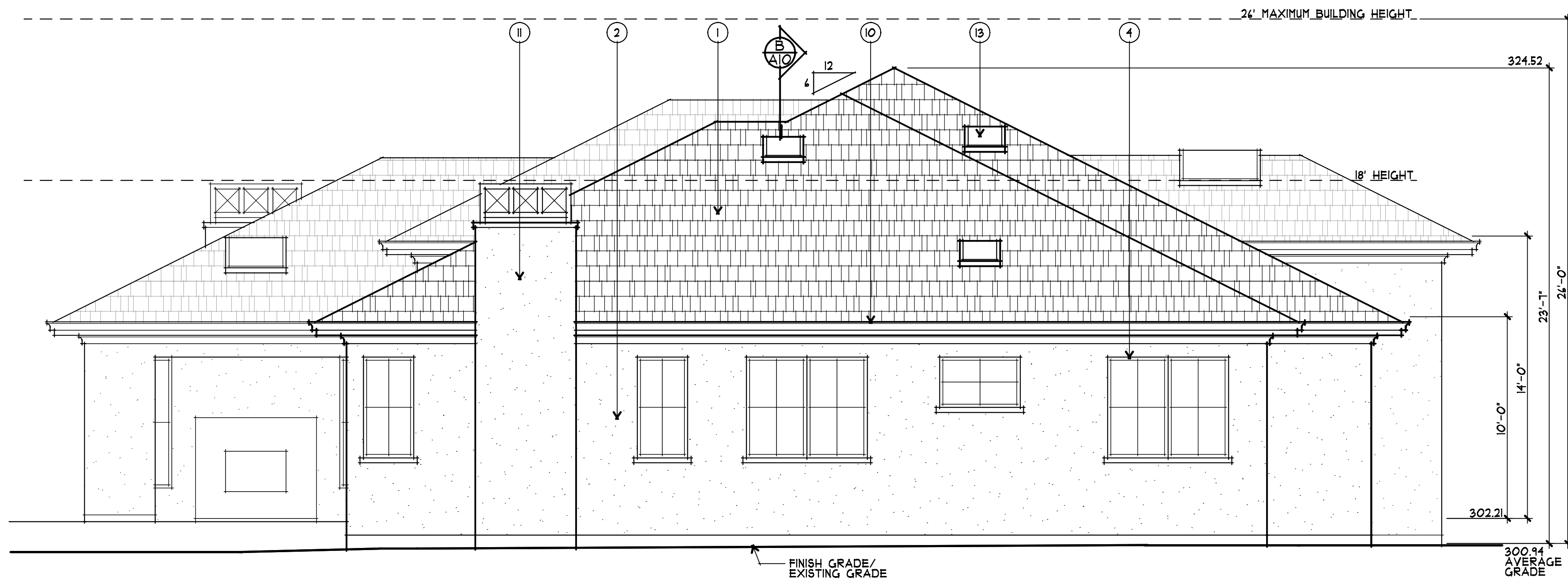

① LEFT (NORTH) ELEVATION
 A7 1/4" = 1'-0"
 0 1 3 6 10

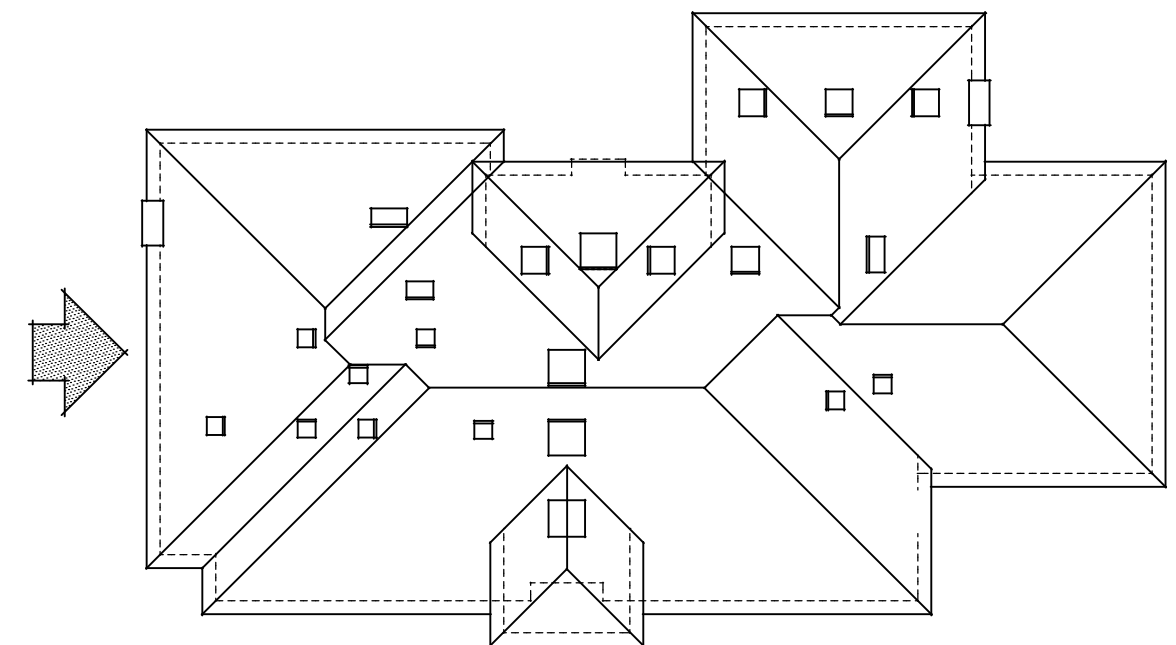

EXTERIOR FINISH SCHEDULE		
LOCATION	KEYNOTE	MATERIAL/COLOR
ROOF	①	SYNTHETIC SLATE ROOF TILE
WALLS	②	STUCCO WITH SMOOTH TROWEL FINISH
	③	
WINDOWS	④	ALUMINUM CLAD WOOD WINDOWS
DOORS	⑤	WOOD ENTRY DOOR W/ GLASS & SIDELITES
	⑥	CARRIAGE-STYLE, OVERHEAD SECTIONAL GARAGE DOOR W/ LITES
	⑦	WOOD FRENCH DOOR(S)
	⑧	WOOD SLIDING DOOR(S)
RAILINGS	⑨	TEMPERED GLASS
GUTTERS & DOWNSPOUTS	⑩	G.I. SHAPED GUTTER W/ RECTANGULAR DOWNSPOUTS
CHIMNEY	⑪	STUCCO WITH SMOOTH TROWEL FINISH
FLASHING	⑫	G.I. FLASHING - PAINT
SKYLIGHTS	⑬	CURB-MOUNTED BY VELUX OR EQ.

ASSOCIATES ARCHITECTS
 11010 combe rd. ste. 210
 AUBURN, CA 95602
 530-268-3055
 J. STEVE COLLOM
 rhaarchitects.com
 rhaassoc@bcglobal.net

LICENSED ARCHITECT
 J. STEVE COLLOM
 No. C 11982
 Exp. 10-21
 STATE OF CALIFORNIA

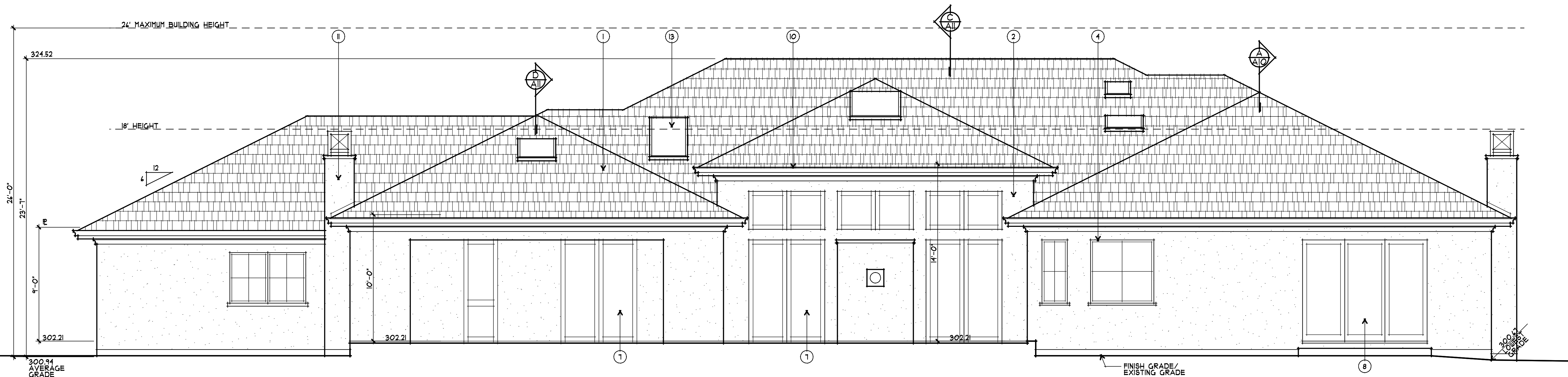

② REAR (EAST) ELEVATION
 A7 1/4" = 1'-0"
 0 1 3 6 10

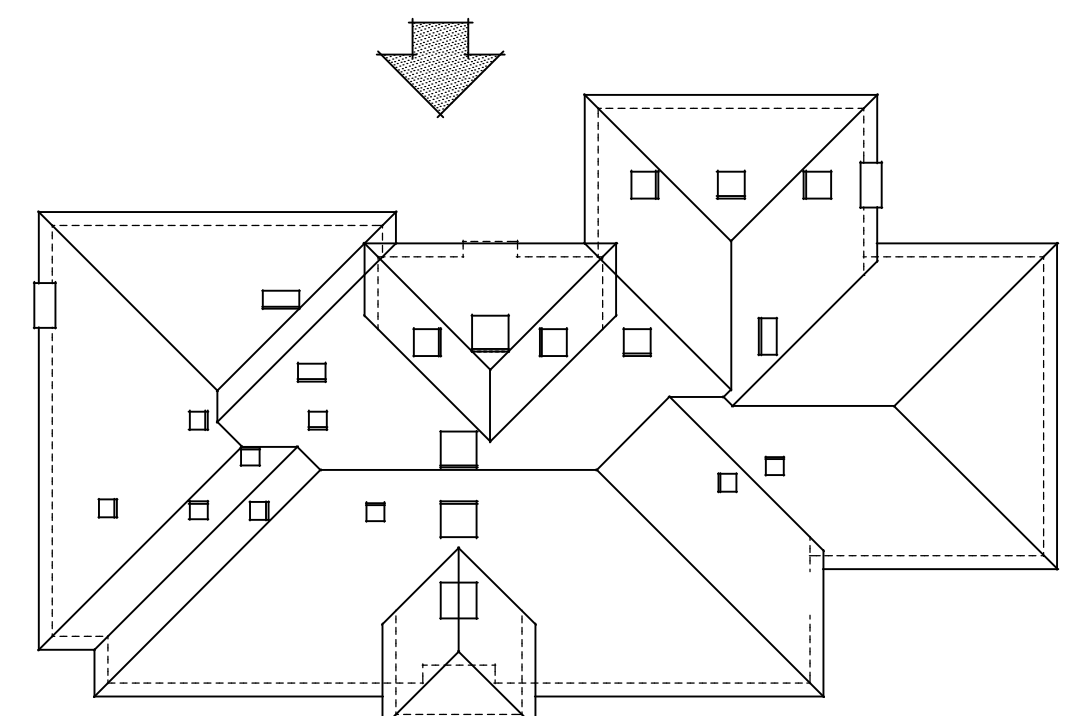

A PROPOSED REMODEL & ADDITION FOR:
MR. STUART WELLS
 14020 ARCADIA PALMS DRIVE SARATOGA, CALIFORNIA

drawings	EXTERIOR ELEVATIONS
revisions	
project number	2576
date	8/1/23
sheet number	A7

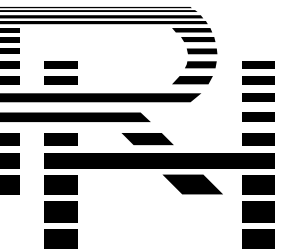

ASSOCIATES
ARCHITECTS
11010 combe rd. ste. 210
AUBURN, CA 95602
530-268-3055
J. STEVE COLLOM
rhaarchitects.com
rhasoc@sbglobal.net

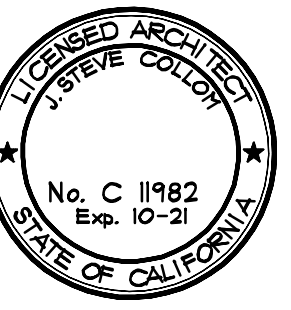

A PROPOSED REMODEL & ADDITION FOR:
MR. STUART WELLS
14020 ARCADIA PALMS DRIVE SARATOGA, CALIFORNIA

drawings
BUILDING
SECTION

revisions

project number
2576

date
8/1/23

sheet number

A8

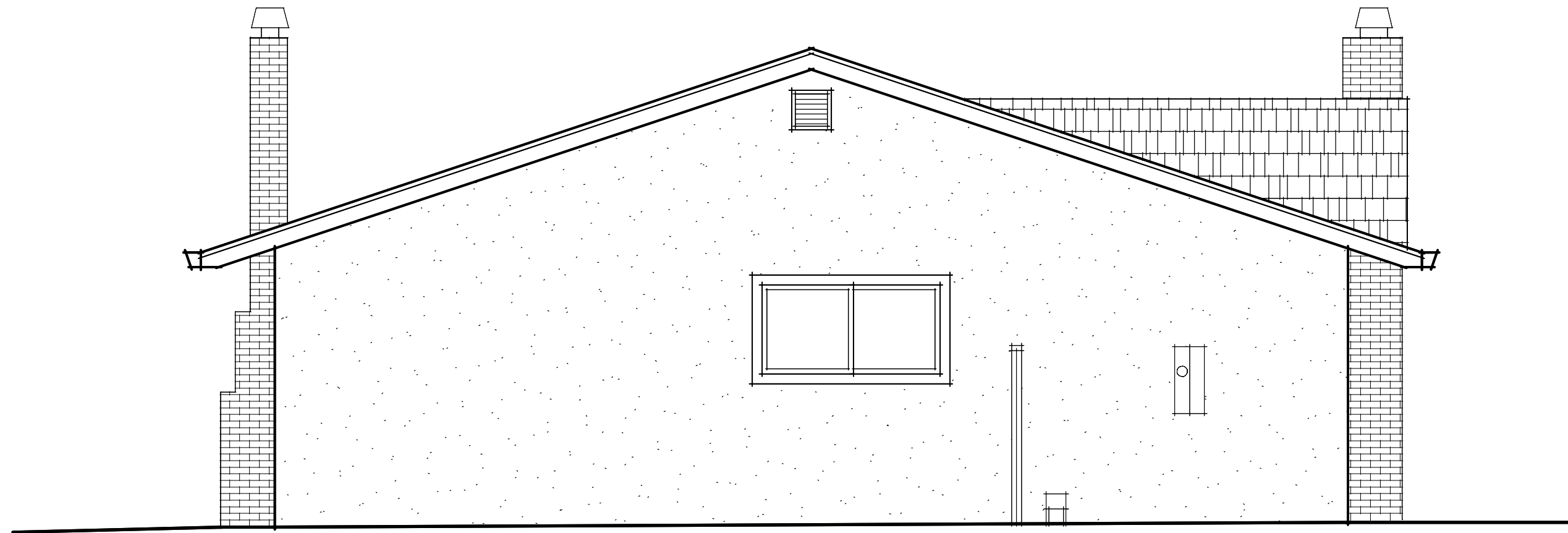

1 LEFT (NORTH) ELEVATION
A8 1/4" = 1'-0" 0 1 3 6 10

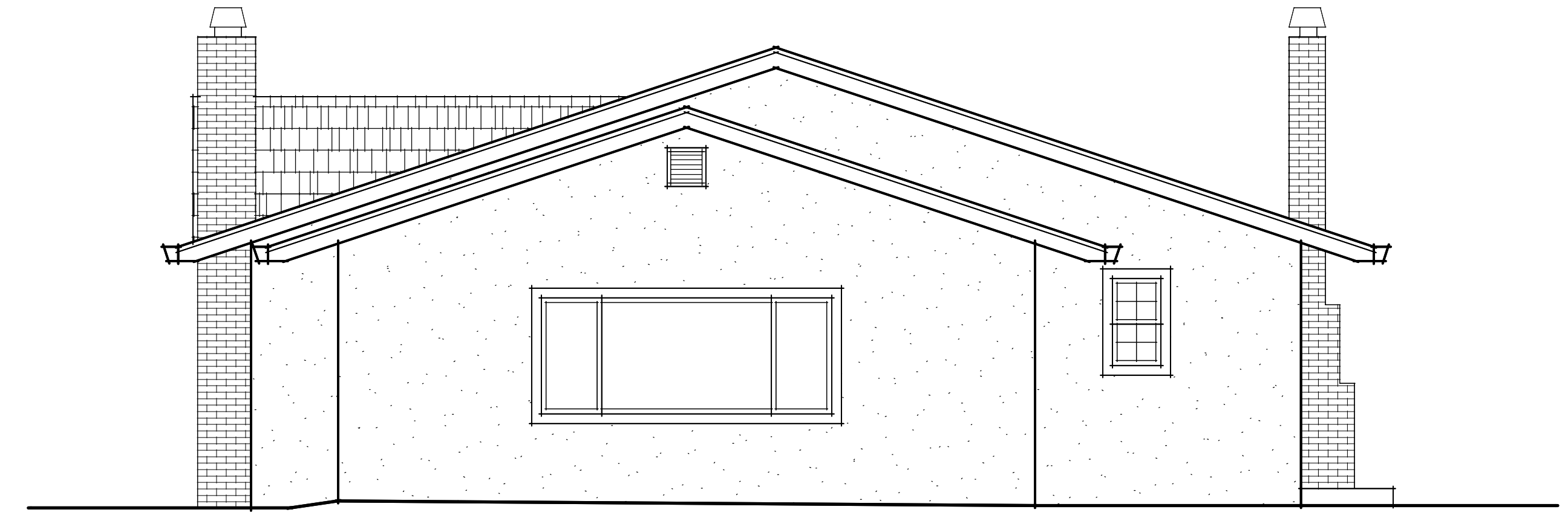

2 RIGHT (SOUTH) ELEVATION
A8 1/4" = 1'-0" 0 1 3 6 10

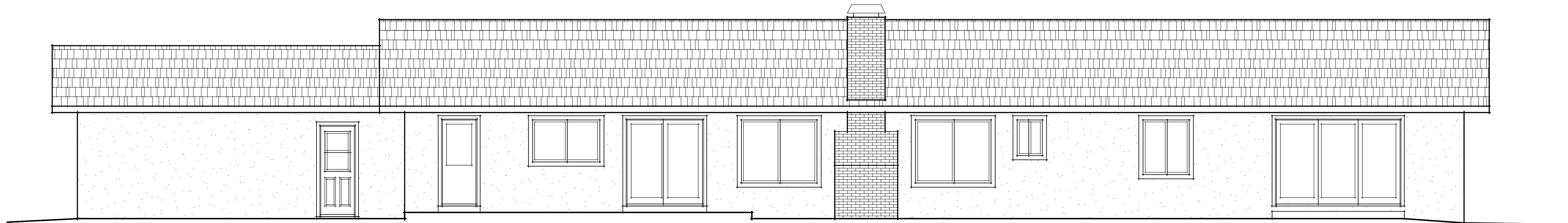

3 REAR (EAST) ELEVATION
A8 1/4" = 1'-0" 0 1 3 6 10

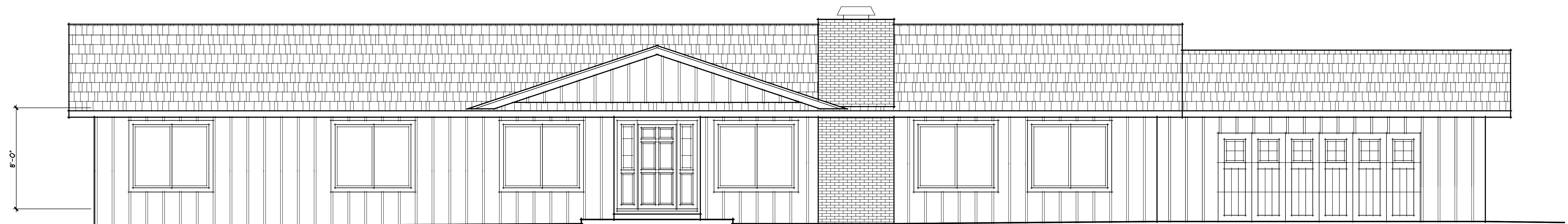

4 FRONT (WEST) ELEVATION
A8 1/4" = 1'-0" 0 1 3 6 10

24' MAXIMUM BUILDING HEIGHT

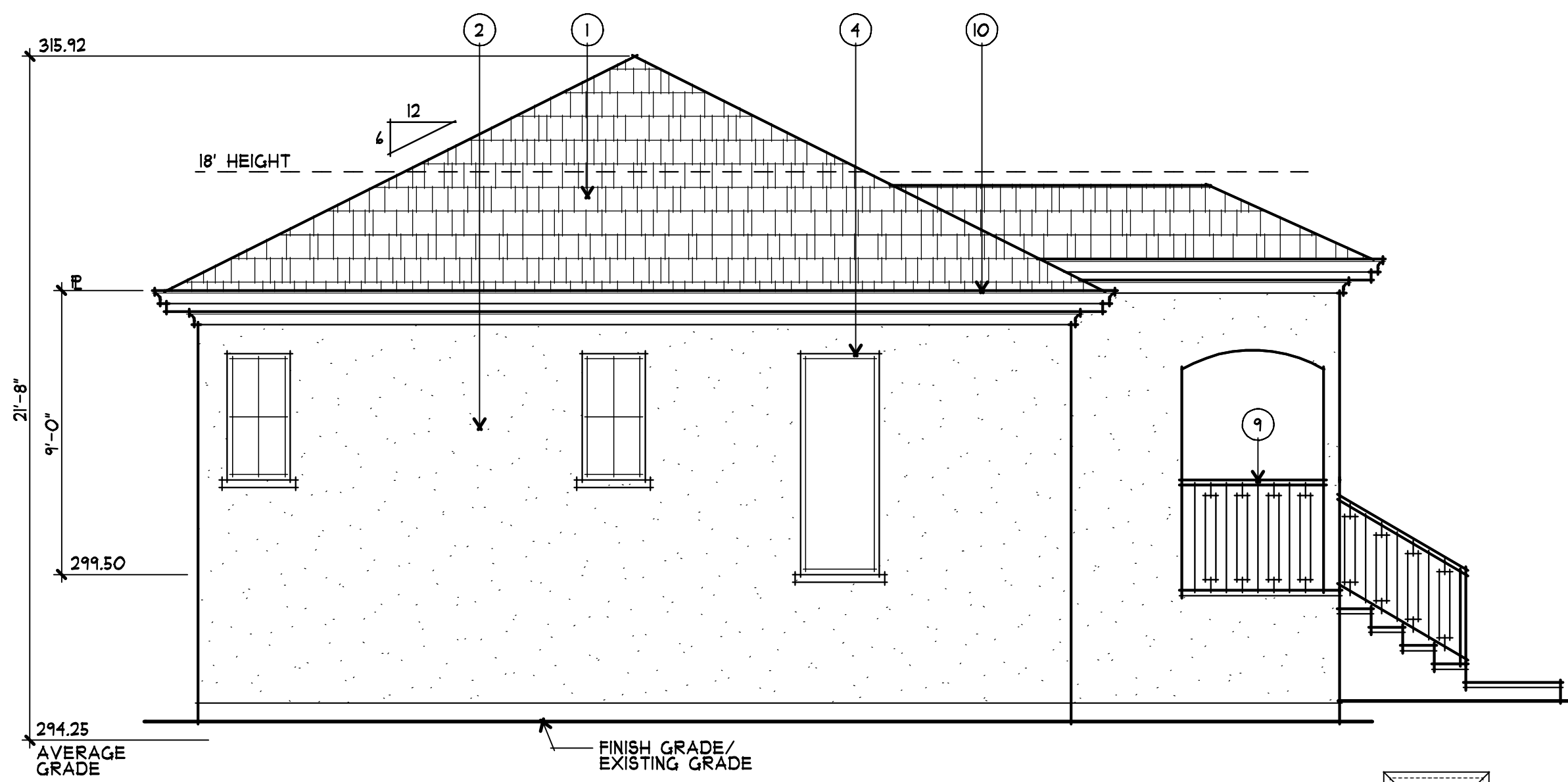

1 LEFT A.D.U. (WEST) ELEVATION
 A9 1/4" = 1'-0" 0 1 3 6 10

24' MAXIMUM BUILDING HEIGHT

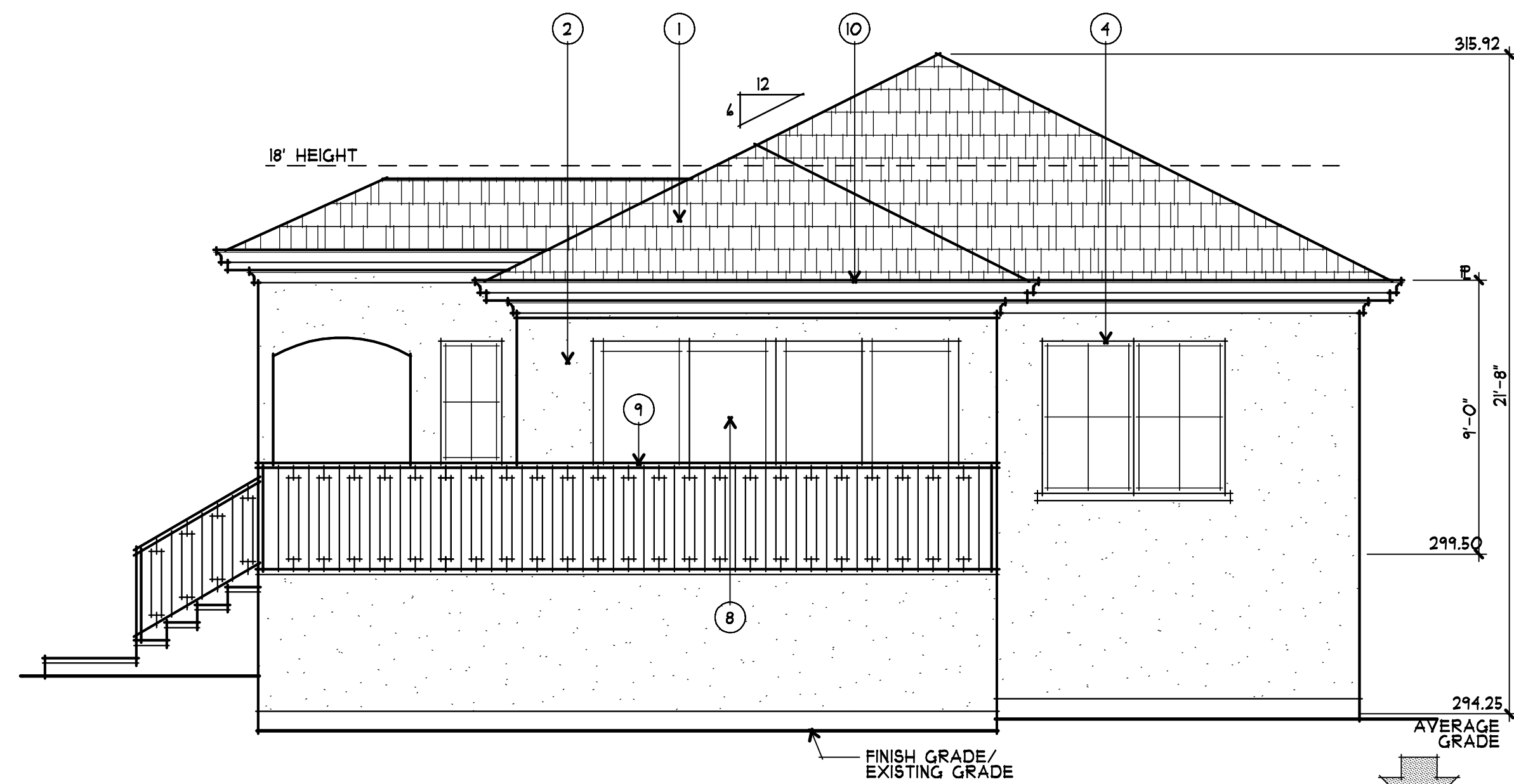

2 RIGHT A.D.U. (EAST) ELEVATION
 A9 1/4" = 1'-0" 0 1 3 6 10

EXTERIOR FINISH SCHEDULE		
LOCATION	KEYNOTE	MATERIAL/COLOR
ROOF	1	SYNTHETIC SLATE ROOF TILE
WALLS	2	STUCCO WITH SMOOTH TROWEL FINISH
	3	
WINDOWS	4	ALUMINUM CLAD WOOD WINDOWS
DOORS	5	WOOD ENTRY DOOR W/ GLASS
	6	
	7	WOOD FRENCH DOOR(S)
	8	WOOD SLIDING DOOR(S)
RAILINGS	9	WROUGHT IRON
GUTTERS & DOWNSPOUTS	10	G.I. SHAPED GUTTER W/ RECTANGULAR DOWNSPOUTS
	11	
FLASHING	12	G.I. FLASHING - PAINT
	13	

ASSOCIATES ARCHITECTS
 11010 combie rd. ste. 210
 AUBURN, CA 95602
 530-268-3055
 J. STEVE COLLOM
 rhaarchitects.com
 rhaassoc@abeglobal.net

LICENSED ARCHITECT
 J. STEVE COLLOM
 No. C 11982
 Exp. 10-21
 STATE OF CALIFORNIA

24' MAXIMUM BUILDING HEIGHT

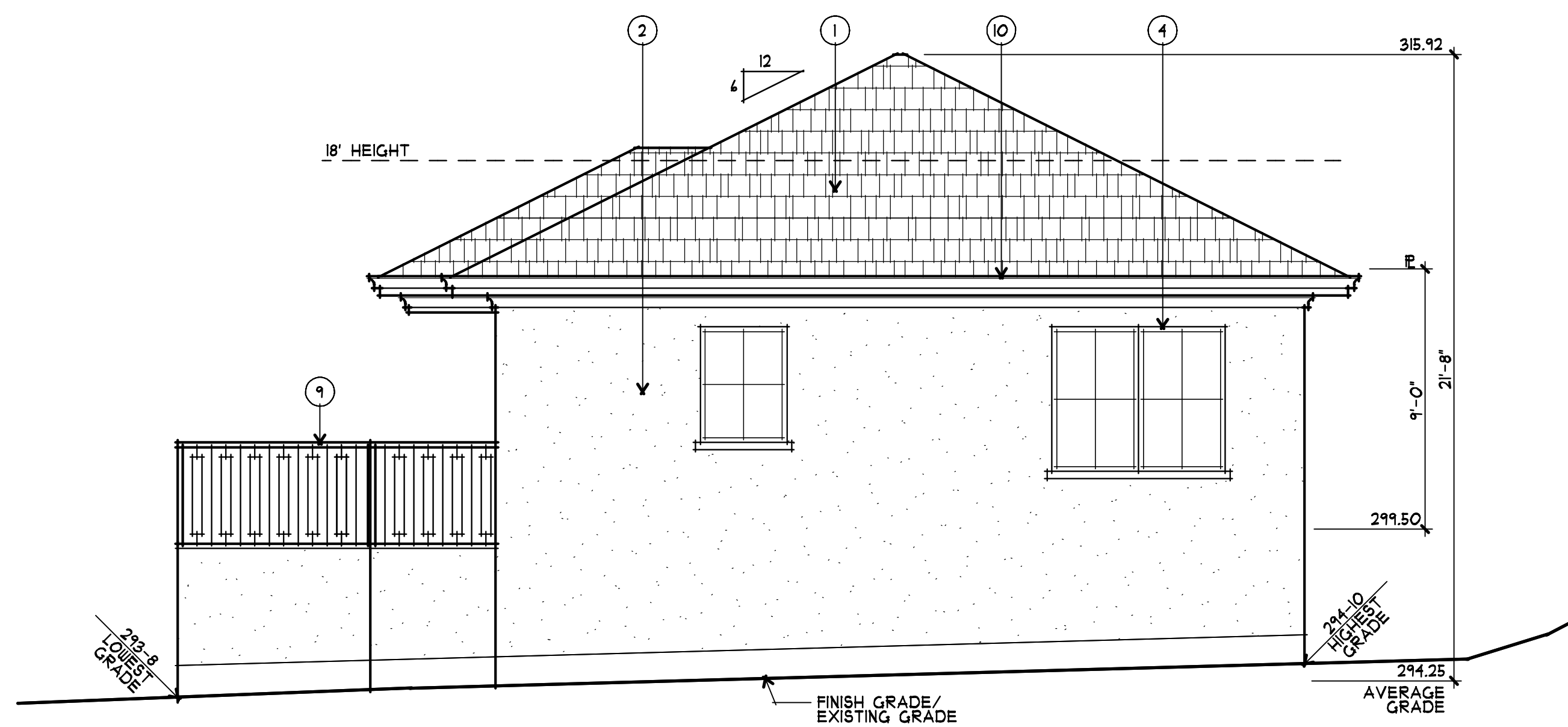

3 REAR A.D.U. (NORTH) ELEVATION
 A9 1/4" = 1'-0" 0 1 3 6 10

24' MAXIMUM BUILDING HEIGHT

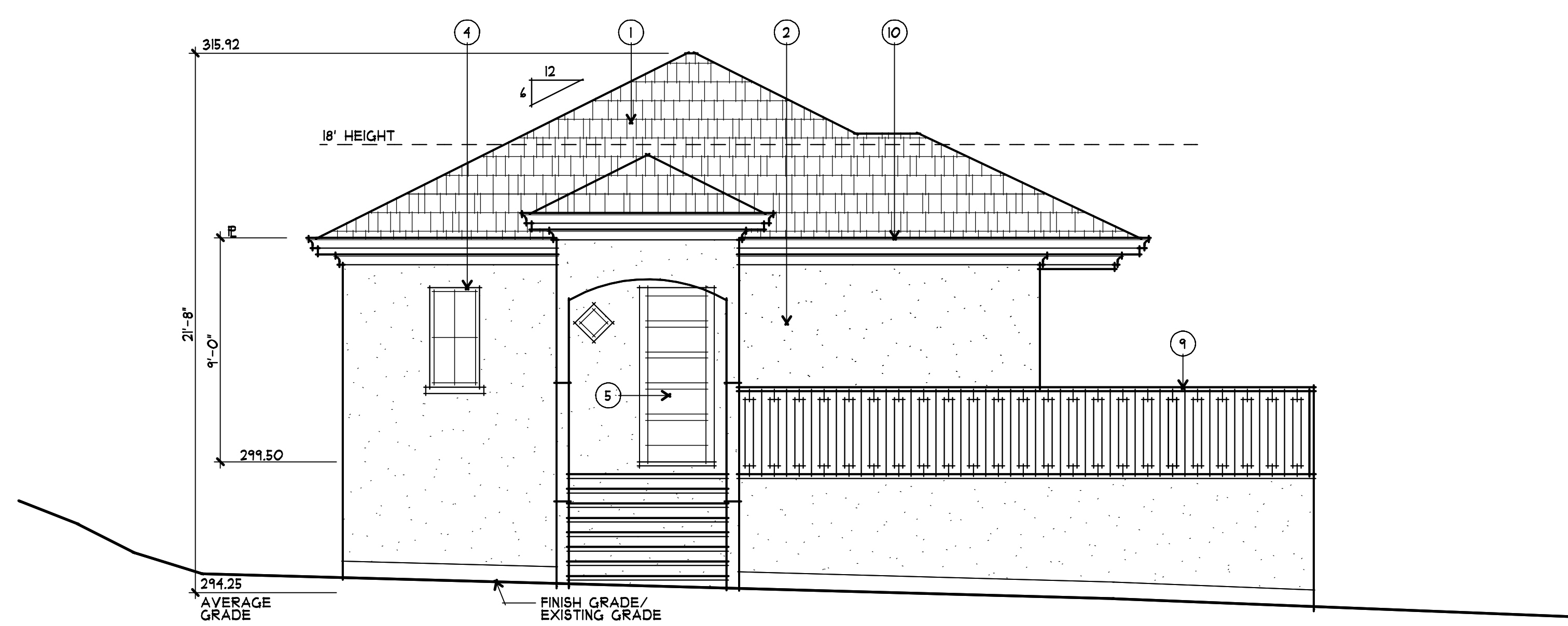

4 FRONT A.D.U. (SOUTH) ELEVATION
 A9 1/4" = 1'-0" 0 1 3 6 10

A PROPOSED REMODEL & ADDITION FOR:
MR. STUART WELLS
 14020 ARCADIA PALMS DRIVE SARATOGA, CALIFORNIA

drawings	EXTERIOR ELEVATIONS
	BUILDING SECTIONS
revisions	
project number	2576
date	8/1/23
sheet number	A9

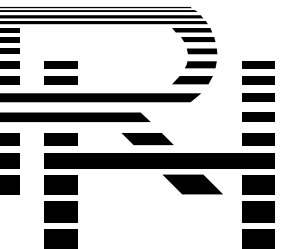

ASSOCIATES
ARCHITECTS
11010 combie rd. ste. 210
AUBURN, CA 95602
530-268-3055
J. STEVE COLLOOM
rhaarchitects.com
rhaassoc@bcglobal.net

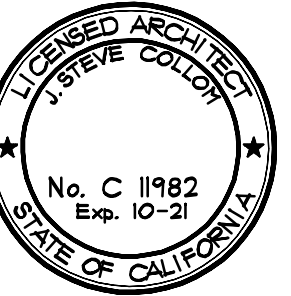

A PROPOSED REMODEL & ADDITION FOR:
MR. STUART WELLS
14020 ARCADIA PALMS DRIVE SARATOGA, CALIFORNIA

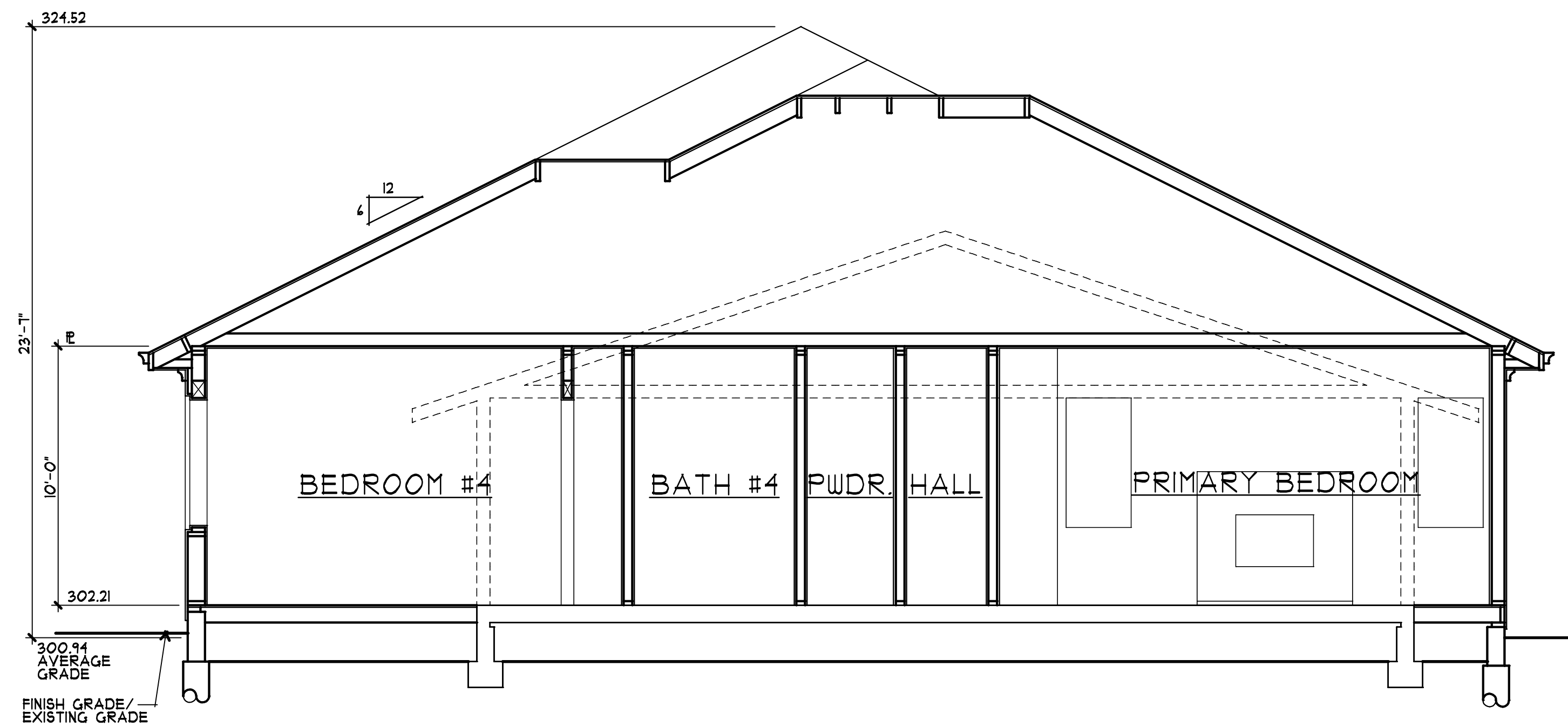

(A) BUILDING SECTION
1/4" = 1'-0"
0 1 3 4 10

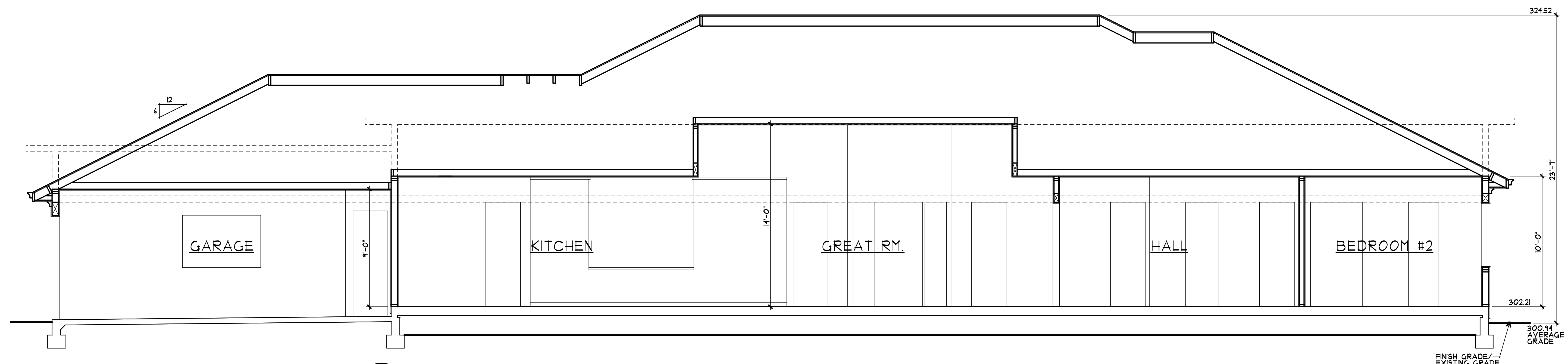

(B) BUILDING SECTION
1/4" = 1'-0"
0 1 3 4 10

drawings	BUILDING SECTIONS
revisions	
project number	2576
date	8/7/23
sheet number	A10

A10

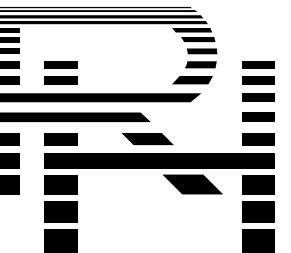

ASSOCIATES
ARCHITECTS
11010 combie rd. ste. 210
AUBURN, CA 95602
530-268-3055
J. STEVE COLLOM
rhaarchitects.com
rhaassoc@bcglobal.net

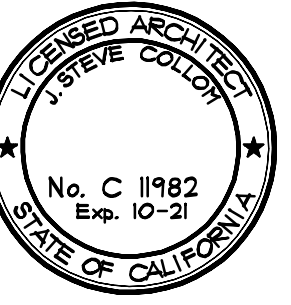

A PROPOSED REMODEL & ADDITION FOR:
MR. STUART WELLS
14020 ARCADIA PALMS DRIVE SARATOGA, CALIFORNIA

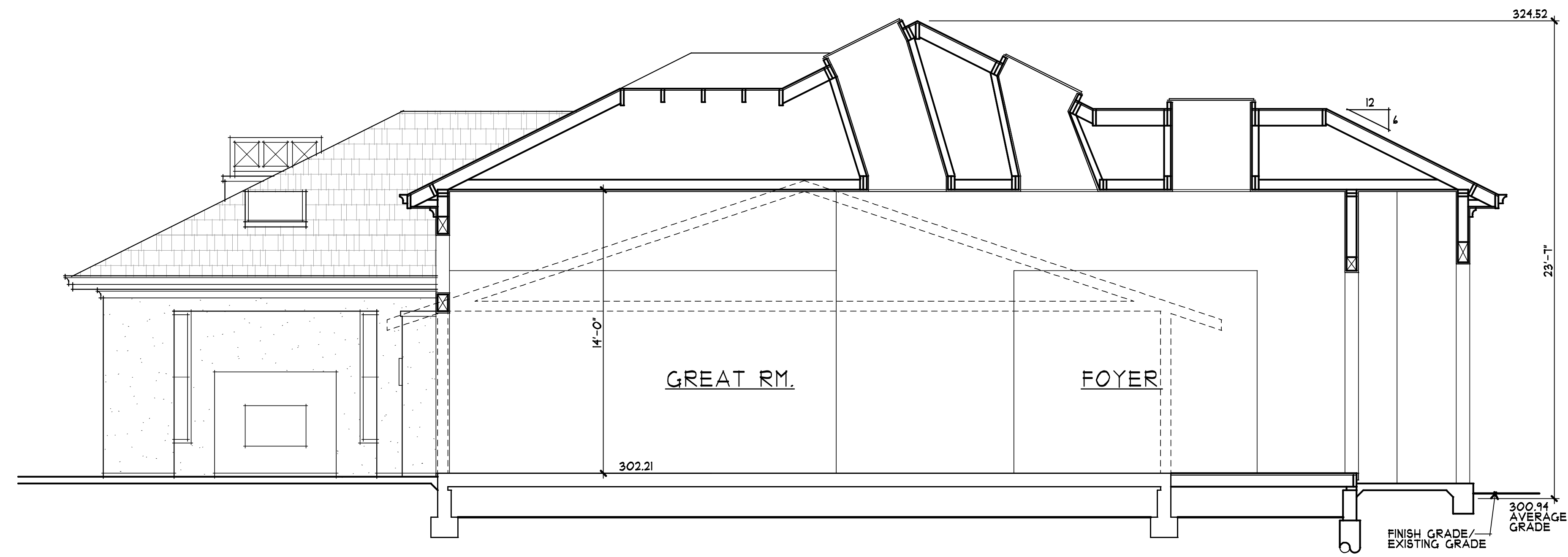

C BUILDING SECTION
All 1/4" = 1'-0"
0 1 3 6 10

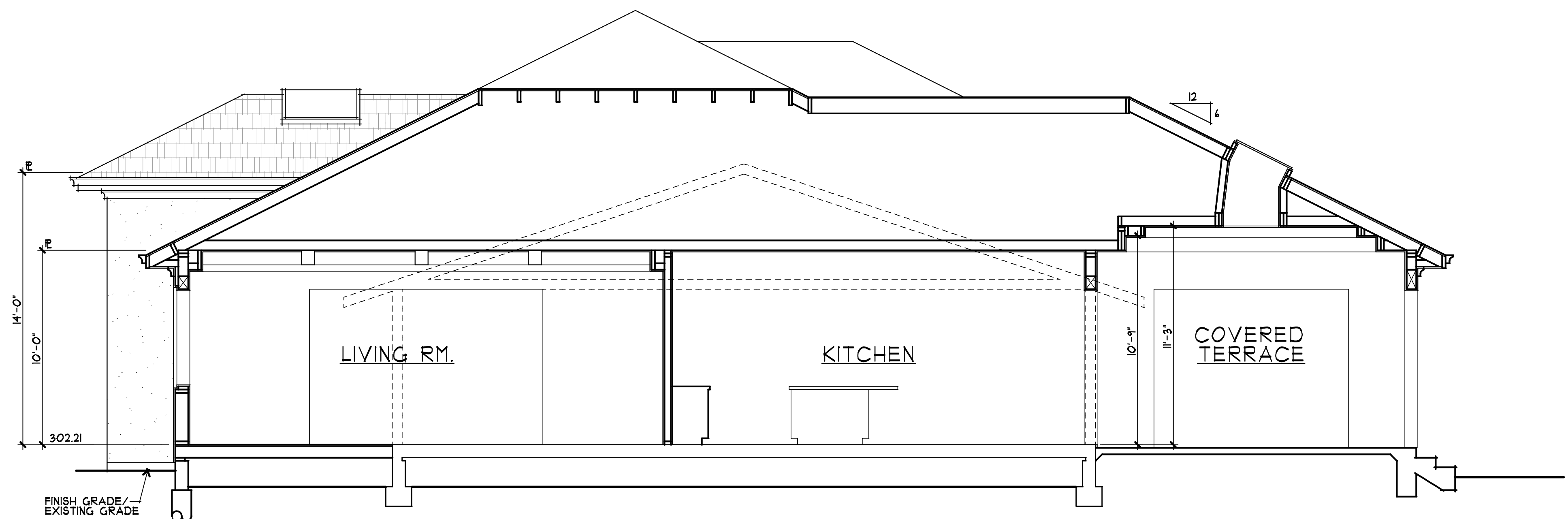

D BUILDING SECTION
All 1/4" = 1'-0"
0 1 3 6 10

drawings	BUILDING SECTIONS
revisions	
project number	2576
date	8/1/23
sheet number	A11

A11