

**PEREZ P&S LLC  
\_\_\_\_ KEAHI CT  
BASTROP, TX  
.37 ACRES  
PID 23699**

**ON-SITE SEWAGE FACILITY  
AEROBIC TREATMENT W/ DRIP IRRIGATION**

**DESIGNED BY:  
KAREL ZALESKI, R.S. #3084  
325-227-7165  
karelzaleski@hotmail.com**



08/21/2025

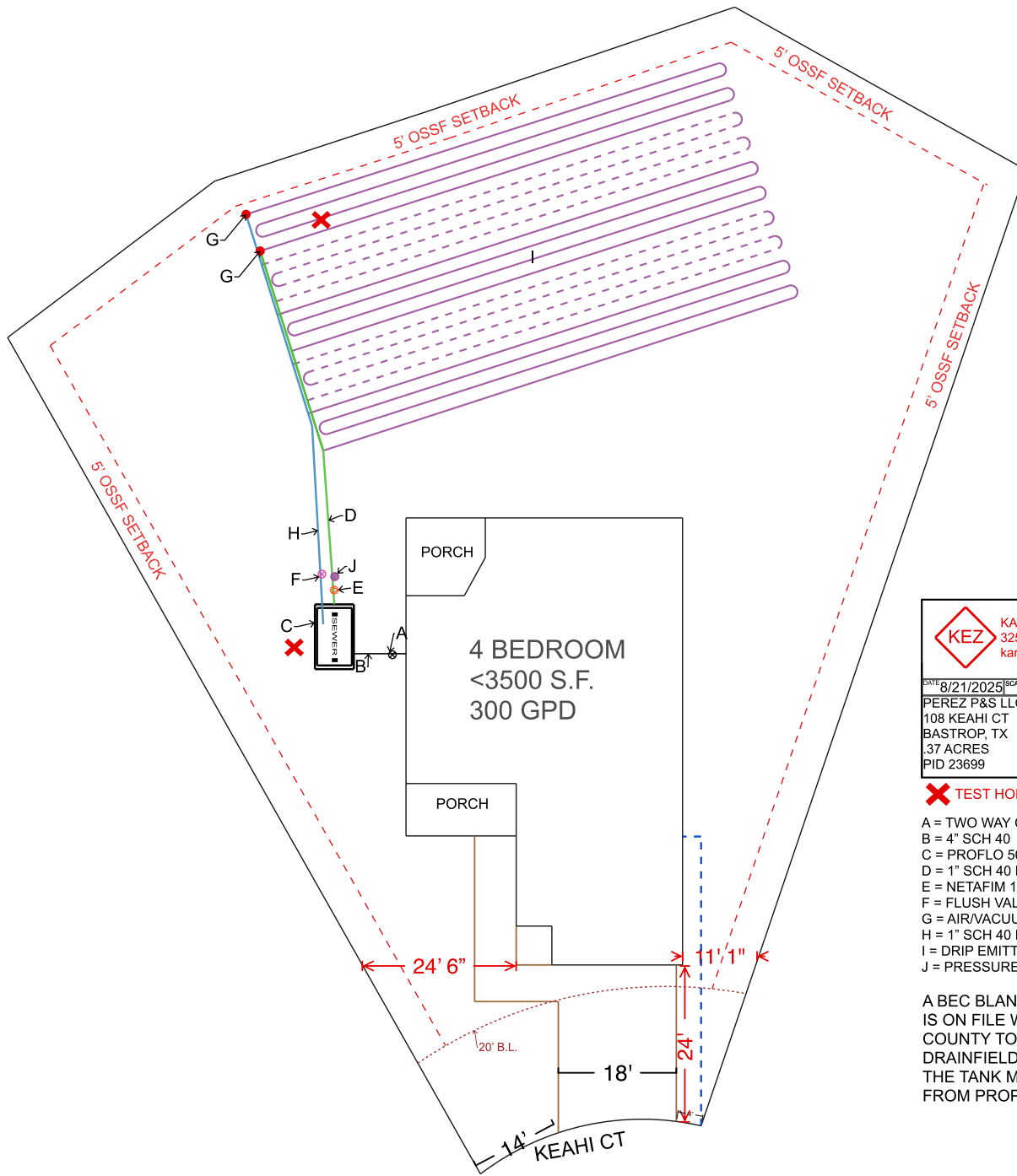

	KAREL ZALESKI, RS #3084 325-227-7165 karelzaleski@hotmail.com	
	DATE: 8/21/2025 SCALE: 1"=25' PEREZ P&S LLC 108 KEAHI CT BASTROP, TX 37 ACRES PID 23699	AEROBIC TREATMENT W/ DRIP IRRIGATION

- TEST HOLES
- Water
- A = TWO WAY C/O
- B = 4" SCH 40
- C = PROFLO 500 SLPT2
- D = 1" SCH 40 DIST LINE
- E = NETAFIM 1" EFFLUENT FILTER
- F = FLUSH VALVE
- G = AIR/VACUUM RELEASE VALVE
- H = 1" SCH 40 RETURN LINE
- I = DRIP EMITTER TUBING
- J = PRESSURE REG - 40 PSI

A BEC BLANKET LETTER IS ON FILE WITH BASTROP COUNTY TO ALLOW DRAINFIELD IN EASEMENT. THE TANK MUST BE 10' FROM PROPERTY LINE

# OSSF Soil & Site Evaluation

Page 1 (Soil & Site Evaluation)

Date Performed: 8 / 4 / 2025

Property Owner: \_\_\_\_\_

Site Location: KEAHI CT PID 23699 Proposed Excavation Depth: 1'

**REQUIREMENTS:**

At least two soil excavations must be performed on the site, at opposite ends of the proposed disposal area. Locations of soil borings or dug pits must be shown on the site drawing. For subsurface disposal, soil evaluations must be performed to a depth of at least two feet below the proposed disposal field excavation depth. For surface disposal, the surface horizon must be evaluated. Describe each soil horizon and identify any restrictive features on this form. Indicate depths where features appear.

Soil Boring Number:					
Depth (Feet)	Texture Class	Gravel Analysis (If Applicable)	Drainage (Mottles/ Water Table)	Restrictive Horizon	Observations
1 FT.	IV	<20%	NONE		CLAY
2 FT.					
3 FT.					
4 FT.					
5 FT.					

Soil Boring Number:					
Depth (Feet)	Texture Class	Gravel Analysis (If Applicable)	Drainage (Mottles/ Water Table)	Restrictive Horizon	Observations
1 FT.	IV	<20%	NONE		CLAY
2 FT.					
3 FT.					
4 FT.					
5 FT.					

### FEATURES OF SITE AREA

- |  |   |
|--|---|
| Presence of 100 year flood zone                                  | <input type="checkbox"/> Yes <input checked="" type="checkbox"/> No |
| Presence of upper water shed                                     | <input type="checkbox"/> Yes <input checked="" type="checkbox"/> No |
| Presence of adjacent ponds, streams, water impoundments          | <input type="checkbox"/> Yes <input checked="" type="checkbox"/> No |
| Existing or proposed water well in nearby area (within 150 feet) | <input type="checkbox"/> Yes <input checked="" type="checkbox"/> No |
| Ground Slope   | <u>3</u> %  |

I certify that the findings of this report are based on my field observations and are accurate to the best of my ability.

*Karel Zaleski*

(Signature of person performing evaluation)  
Form # PA5/030204-Final

8/4/2025  
(Date)

OS#10180  
Registration Number and Type

## CALCULATIONS AND SPECIFICATIONS

Required Drip Area (SA) = Q/Ri

Q = daily usage rate

Ri = effluent loading rate in gal/sq. ft./day

Therefore: S.A. = 300/.1

S.A. = **3000 sq. ft.**

Aerobic Treatment Unit Sizing for Single Family Residences - Chapter 285.91(2), Table 4 Bedroom and < 3500 sq. ft. = **360 gpd** Minimum Aerobic tank treatment capacity

System will utilize a **ProFlo 500 SLPT2**

400 gallon Pretreatment trash tank

500 gallon 2<sup>nd</sup> compartment

771 gallon pump tank

The control panel shall be a SPI Model Aerobic Control Panel and the timer shall be an Intermatic FM/1. The timer will be set to dose 4 times per day

### **Flow Rates:**

Emitter spacing – 2 ft. centers

Emitter line required 3000 sq ft/ 2 ft spacing = 1500 linear feet

Number of emitters = 3000 sq ft / 4 sq ft/emitter = 750 emitters

Emitter flow rate = 0.6 gal/hour

Total flow = 750 emitters x .6 gal/emitter/hr = 450 gal/hour

450 gal/hour/60 min/hr = 7.5 gpm

It has been established that proper scouring and flushing of any pipes will require at least 1.6 gallons per minute flow at the outflow end of any pipe. Therefore, we should require a flow of at least 1.6 gpm out of each dipper line connection that has been made to the return flush manifold pipe.

The field will have 5 connections from the dist. line: (see site plan)

5 loops = 300 l.f. (4 lines @ 75') = 1500'

**Flow rates and pump sizing:** 2.0 f.p.s.

5 connections x 1.6 gpm = 8.0 gpm

Total Flow = 7.5 gpm + 8.0 gpm = **15.5 gpm**

### **Head Calculation:**

Supply line loss 4.5/2.31 = 1.9 psi/100' of 1" x 55 ft = 1.0 psi

Return line loss 4.5/2.31 = 1.9 psi/100' of 1" x 60 ft = 1.1 psi

Pressure required at the inlet of the drip tubing =	40.00 psi
Elevation from the pump to the highest drip tubing inlet = 4 ft/2.3 psi/ft =	1.70 psi
Supply line loss = 1.9 psi/100 ft x 55' =	1.0 psi
<b>Total =</b>	<b>42.7 psi</b>

**Head Pressure Calculation:**

Elevation head:

Tank Depth = 4.6 feet

Field Elevation = 1.0 feet

**Total elevation friction head = 5.6 ft**

Friction Head Loss:

Diameter of distribution pipe = 1"

Length of distribution pipe = 55'

Friction head loss per 100 feet of 1" Sch 40 pipe at 15.5 gpm =

Supply line = 55'/100' x 5.7 ft = 3.1 feet

Return line = 60'/100' x 5.7 ft = 3.4 feet

Spin filter = 2.5 feet

Loss through emitters **9.0 feet**

Pressure Head Loss:

**Pressure = 40 psi x 2.31 = 92.4 feet**

**Total Head = 5.6 ft + 9.0 ft + 92.4 ft = 107 Feet**

**Pump requirement:**

Sta-Rite S.T.E.P. Plus Model 20DOM05121 submersible pump capable of achieving 15.5 gpm @ 107 feet.

**Dosing:**

300 gpd @ 4 doses per day = 75 gallons. 75 gallons dose @ 7.5 gpm = 10 minutes of dosing time. The pump is proposed to activate via timer once every 6 hours.

**Pump Chamber:**

Float settings based on tank manufacturer specs

Bottom of inlet = 55"

Liquid capacity is 771 gallons (14.01" per gallon)

Minimum 240 gallons above alarm provided

Pump off @ 8" (112.1 gallons)

Pump on @ 10" (28.0 gallons)

High water alarm @ 32" (308.2 gallons)

322.7 Gallons reserved from outlet to high water alarm (> 1/3 days required)

(SEE ATTACHED TANK DETAILS)

## Design Specifications

1. The property is located at \_\_\_\_ Keahi Ct., Bastrop, TX. The proposed structure is a single-family home with 4 bedrooms less than 3500 sq. ft. Water supply to the home will be furnished by public water. The property is in Zone X according to the FEMA flood map panel 355F. The site evaluation indicates the site is suitable for a Drip Irrigation OSSF System. Low flow water rate fixtures shall be installed throughout the residence.
2. The daily maximum water usage is 300 gallons per day. (water saving devices)
3. Effluent from the home will be conveyed to the septic tank through a solid wall 3" or 4" SCH 40 pipe with a minimum slope of 1/8" per foot. A two-way clean out will be provided between the house and septic tank. All piping from the house to tank must be bedded with a minimum of 4" of class Ib, II, or III soils with less than 30% gravel and free of gravel greater than 1/2" in diameter.
4. ProFlo 500 SLPT2 treatment unit will be installed and utilized. The total plant volume is 900 gallons with a 771 gallon pump tank. The tank shall be placed set level within 1" set on a minimum of 4" of sand, sandy loam, clay loam or pea gravel then backfilled with sand or sandy loam. The controls for the pump system shall include a switching control for turning the pump on and off and a high water alarm, which consists of a light bulb, and audible alarm in an accessible place for monitoring
5. All electrical wiring shall be in accordance with the most recent edition of the National electric code. Connections shall be in approved junction boxes and all external power wiring shall be in approved electrical conduit.
6. Tank must be water tight and sealed with an impervious seal. The tank shall be covered by a minimum of 12' ground cover, if the tank(s) is installed with more than 12" ground cover then risers will be required. Set tank level on minimum 4" of sand. Tank excavations must be backfilled with soil (Ib, II or III) or pea gravel that is free of rock larger than 1/2" diameter.
7. All risers installed on each cleanout shall extend to finish grade if they are larger than 12" in diameter and must have a secondary plug, cap or restraint to prevent tank entry in an event that the primary cover is damaged or missing. All riser lids must be permanently attached to the tank, be water tight and have some form of lock or cover that require tools to remove.
8. "T" branches must be installed in the inlets and outlets portion of each tank with downward extensions.
9. Air vents are required at the highest elevation in the supply line and the return line. A pressure regulator (set at 40 psi) with bypass will be installed in the supply line.

10. The effluent from the septic tank will be conveyed through a 1" sch 40 pipe to a drip irrigation pressure emitter system. *The system will be on timer that should be set to dose 4 evenly spaced doses a day @ 10 minutes per each dose.* All piping from the tank to drainfield must be bedded with a minimum of 4" of class Ib, II, or III soils with less than 30% gravel and free of gravel greater than ½" in diameter.
11. The installer will be placing the Netafim Bioline drip emitter tubing on natural ground. Netafim "flex pipe" with Bioline connections between drip lines and between ends of drip lines and supply/return pipes or u-turns ends of drip tubing must be staples/anchored to the ground to prevent kinking/pinching of the drip tubing. Sandy loam must be placed on top.
12. To prevent plugging of the emitters, it is recommended that field flushing take place on a regular basis. The system will be equipped to use continuous flushing therefore the contents of the lines must be returned to the pump tank. This will clean out the emitter lines, and will help prevent emitter blockage, slime buildup, and inorganic scale buildup. In this process, the velocity of water moving through must be at least 2 feet per second.
13. A vegetative cover shall be placed on top of the drip field to facilitate transpiration. The excavation should also be slightly mounded to prevent storm water from pooling on the drain field.
14. **Potable water lines must be 10' minimum from any component of the OSSF.**
15. No pervious cover may be installed over the septic tank or disposal field. No driving or parking on the disposal field or tank as well. Sprinkler systems are not permitted to spray on disposal area.

Affidavit:

Prior to issuance of a permit, a certified copy of an affidavit must be submitted in the County Clerks office in Bastrop County. The affidavit is recorded filed in reference to the real property deed on which the surface application system is installed on the property.

## Maintenance Requirements:

- The aerobic drip system will require a maintenance contract with a certified maintenance contractor and be furnished to the regulatory authority before a permit will be issued.
- The initial contract will be a minimum of two years.
- The maintenance company will verify that the system is operating properly and provide on-going maintenance of the installation.

The homeowner is primarily responsible for maintaining a properly functioning Aerobic treatment system. The installer is responsible for furnishing the homeowner the installation manual and to instruct the homeowner on the proper use of this type of OSSF. The following maintenance provisions are required by the homeowner:

1. A maintenance contract must be maintained on the system for the first 2 years by a licensed maintenance contractor.
2. The owner is responsible for maintaining a constant supply of chlorine in the system. (if required)
3. The owner must prohibit the discharge of grease into the system.
4. Keep the disposal area mowed and the tank area free of ants and weeds.
5. Maintain all faucets and toilets inside the home free of leaks.
6. Maintaining the pretreatment tanks by pumping out every 3-5 years to avoid sludge build up.
7. Water softeners are prohibited from being discharged in the treatment tank as well as a garbage disposal to dispose of kitchen waste.

*The following design is intended to follow and meet Bastrop County On-Site Sewage Facilities Regulations as well as TCEQ 30 TAC 285 OSSF Regulations. The performance of this system cannot be guaranteed even though all provisions of 30 TAC 285 have been met or exceeded.*

Karel Zaleski, R.S. #3084



08/21/2025

# TANK DETAIL

## PRO FLO 500 SLPT2

### 500 GPD AEROBIC TREATMENT UNIT

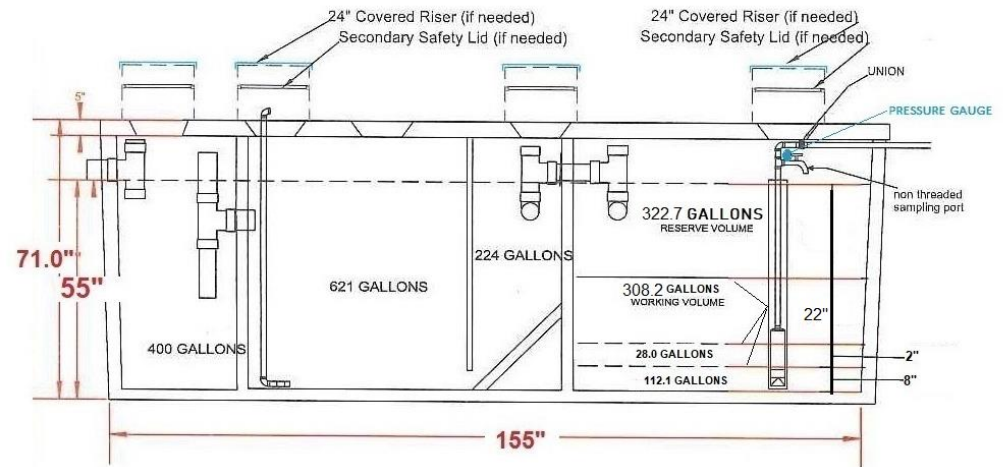
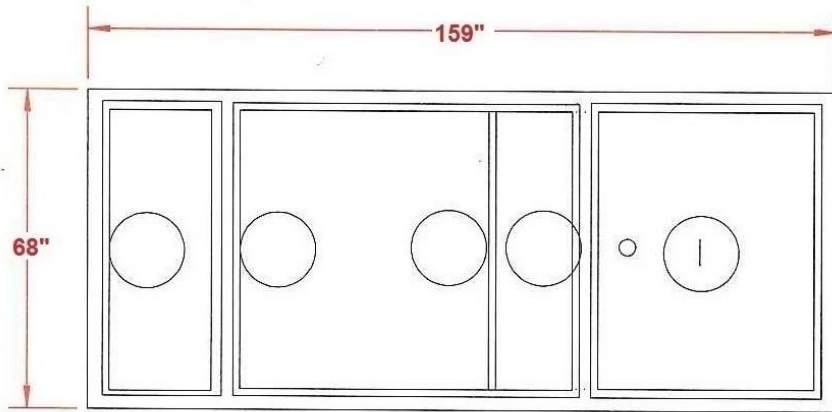

#### SYSTEM COMPONENTS:

- ProFlo 500 SLPT2 treatment tank with 771 gal pump tank
- 400 gallon pretreatment tank
- 621 Aeration Chamber
- Liquid chlorinator
- Audio and Visual Control panel (high water and air)
- 15 minute pin timer - set every 6 hours
- STA-RITE STEP D PLUS EFFLUENT PUMP (or equivalent)
- Factory sampling port

- 8" Pump off @ 112.1 gallons residual
- 10" Pump on @ 28.0 gallons residual
- 32" High water @ 308.2 gallons residual

PRESSURE SHALL NOT EXCEED 40 PSI